



# RECTANGULAR VACUUM CUPS WITH BALL VALVE AND SELF-LOCKING SUPPORT, FOR GLASS

Glass machinery manufacturers require increasingly accurate and safe clamping machines. This has led us to the creation of this series of cups.

The specially designed shape of this cup guarantees a firm grip.

The other main feature is the utmost precision in the height, whose nominal size has a tolerance of only five hundredths of millimetre.

They are composed of:

- A sturdy aluminium support with a wide surface at the base limited by a seal whose purpose is to fix it to the bearing surface.
- A standard rectangular flat cup which is cold-assembled onto the upper part of the support for gripping the load.
- A ball valve that opens up creating vacuum, only when activated by the load to be gripped.
- Two quick couplings for vacuum connection.

The detection of vacuum, for gripping and releasing the support from the bearing surface and for gripping and release of glass can be made via three-way vacuum valves or solenoid valves.

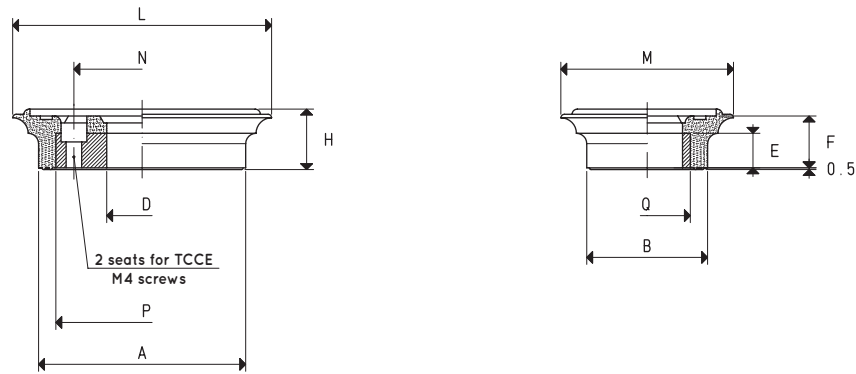

## SPARE VACUUM CUP

Item	Force Kg	Volume cm <sup>3</sup>	A	B	D Ø	E	F	H	L	M	N	P	Q	Support material	Weight g
<b>08 50 75 A</b>	7.5	6.1	60	35	20.5	10	15	17.5	75	50	39.5	50	25	steel	92

Compound: A = oil-resistant rubber

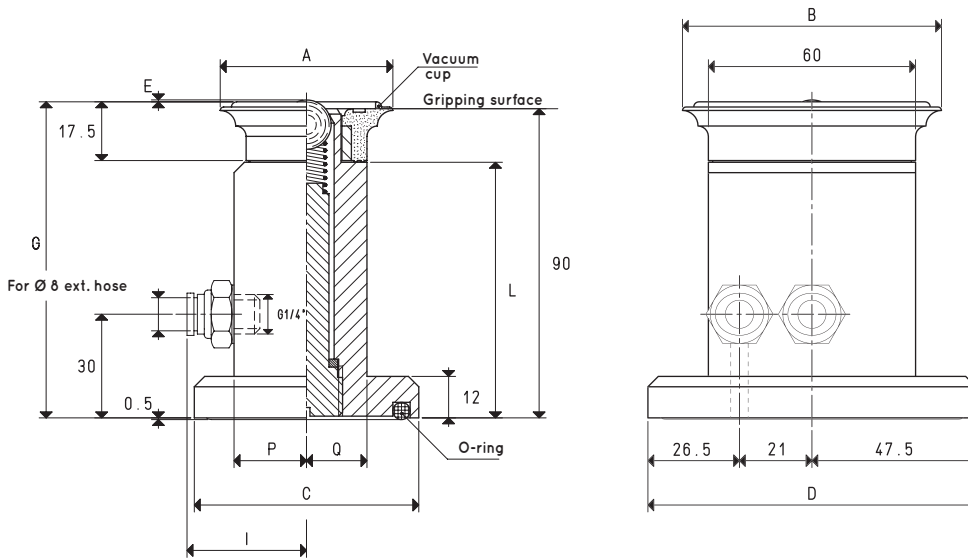

## VACUUM CUP WITH BALL VALVE AND SELF-LOCKING SUPPORT

Item	Force Kg	A	B	C	D	E	G	I	L	P	Q	Vacuum cup item	O-ring item	Weight Kg
<b>18 50 75/90 A</b>	7.5	50	75	65	95	1	92.5	41	75	21	17.5	08 50 75 A	00 16 06	0.762

Compound: A = oil-resistant rubber

Note: The force of the vacuum cups indicated in the table represents 1/3 of the value of the theoretical force calculated at a level of vacuum of -75 KPa and a factor of safety 3.

Transformation ratio: N (newton) = Kg x 9.81 (force of gravity)      inch =  $\frac{\text{mm}}{25.4}$  ; pounds =  $\frac{\text{g}}{453.6} = \frac{\text{Kg}}{0.4536}$