

RECTANGULAR VACUUM CUPS WITH BALL VALVE, SELF-LOCKING SUPPORT AND RELEASE BUTTON

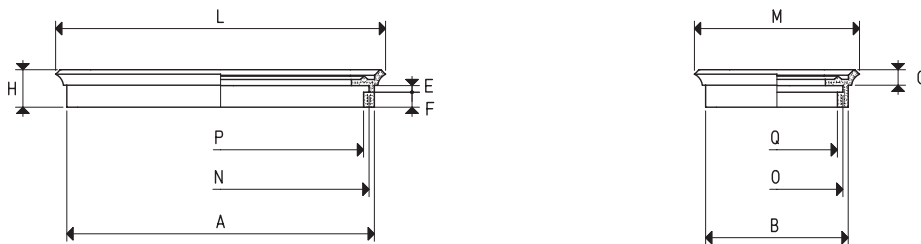

SPARE VACUUM CUPS

Item	Force Kg	Volume cm ³	A	B	E	F	G	H	L	M	N	O	P	Q	Weight g
01 120 90 *	24.0	42.9	107	78	3	7.5	7.5	17.5	117	87	102	73	97	68	38.8
01 150 75 *	25.0	43.5	137	62	3	7.5	7.5	16.5	147	72	132	57	127	52	41.2

* Complete the code indicating the compound: A= oil-resistant rubber; N= natural para rubber; S= silicon

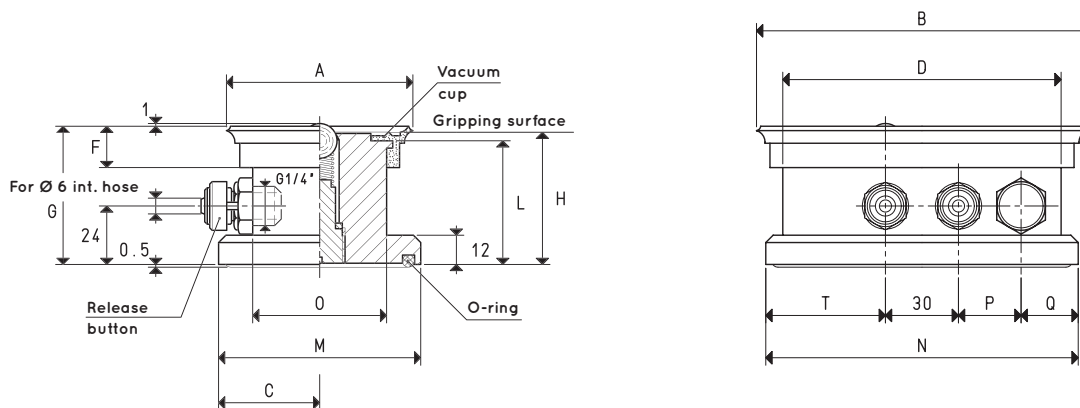

VACUUM CUPS WITH BALL VALVE, SELF-LOCKING SUPPORT AND RELEASE BUTTON

Item	Force Kg	A	B	C	D	F	G	H	L	M	N	O	P	Q	T	Vacuum cup item	O-ring item	Weight Kg
21 120 90 *	24	90	120	56	102	17.5	57.0	54.5	50	98	128	70	24	25	49	01 120 90	00 16 10	1.320
21 150 75 *	25	75	120	48	130	16.5	57.0	54.5	50	83	144	55	25	32	57	01 150 75	00 16 10	1.236
21 150 75/84 *	25	75	150	48	130	16.5	86.5	84.0	80	83	144	55	25	32	57	01 150 75	00 16 10	1.924

* Complete the code indicating the compound: A= oil-resistant rubber; N= natural para rubber; S= silicon

Note: The force of the vacuum cups indicated in the table represents 1/3 of the value of the theoretical force calculated at a level of vacuum of -75 KPa and a factor of safety 3.

Transformation ratio: N (newton) = Kg x 9.81 (force of gravity) inch = $\frac{\text{mm}}{25.4}$; pounds = $\frac{\text{g}}{453.6} = \frac{\text{Kg}}{0.4536}$