



FLAT ROUND VACUUM CUPS WITH VULCANISED SUPPORT, FOR CLAMPING GLASS AND MARBLE

Glass and marble manufacturers' machining centres require increasingly accurate and safe clamping systems. This has led us to creating this new series of cups.

They are vulcanised onto a steel support and are provided with a hole in the centre for vacuum connection or for a ball valve, as well as with 3-4 holes on the internal circumference for housing Allen screws.

Their extremely flexible lip allows them to easily adapt to the sheets to be held, with no risk of deformation or rupture, even for the thinnest ones.

The particular shape of the internal support plane of these cups ensures a high friction coefficient with the gripping surface and especially a considerable grip on wet glass and marble sheets, thanks to the water drainage. All this guarantees a firm, safe grip.

Furthermore, these cups feature the highest accuracy of their thickness, whose nominal height has a tolerance of only five hundredths of millimetre.

They are normally produced with oil-resistant rubber A, but they can be ordered in other compounds, listed on pg. 31, upon request and in minimum quantities to be defined in the order.

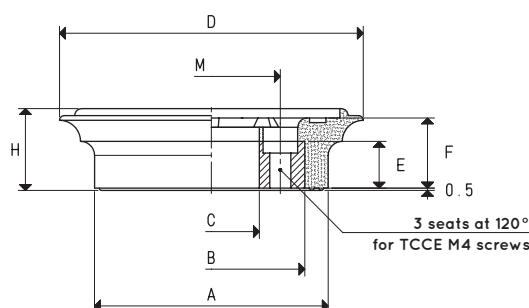

VACUUM CUPS WITH VULCANISED SUPPORT

Item	Force Kg	Volume cm ³	A Ø	B Ø	C Ø	D Ø	E	F	H	M Ø	Support material	Weight Kg
08 65 11 A	6.7	5.5	50	40	20.5	65	10	15	17.5	29.5	steel	0.09
08 85 11 A	12.0	7.7	70	60	40.5	85	10	15	17.5	49.5	steel	0.14

Compound: A = oil-resistant rubber

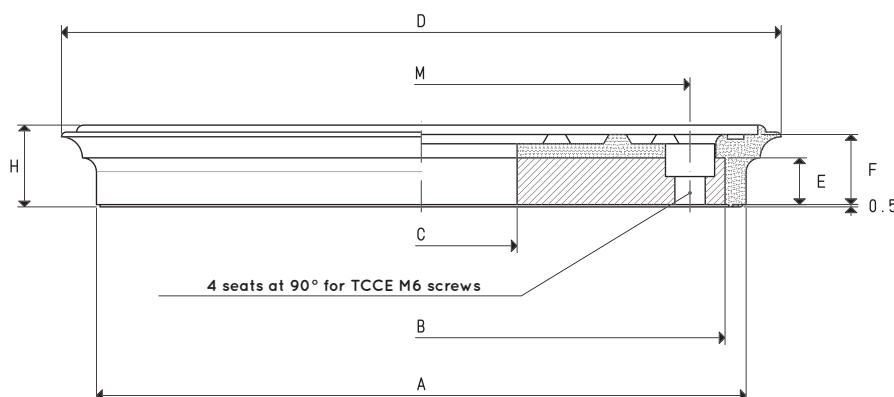

VACUUM CUP WITH VULCANISED SUPPORT

Item	Force Kg	Volume cm ³	A Ø	B Ø	C Ø	D Ø	E	F	H	M Ø	Support material	Weight Kg
08 150 11 A	42.7	47.1	139	130	41	150	10	15	17.5	115	steel	1.0

Compound: A = oil-resistant rubber

Note: The force of the vacuum cups indicated in the table represents 1/3 of the value of the theoretical force calculated at a level of vacuum of -75 KPa and a factor of safety 3.

Transformation ratio: N (newton) = Kg x 9.81 (force of gravity) inch = $\frac{\text{mm}}{25.4}$; pounds = $\frac{\text{g}}{453.6} = \frac{\text{Kg}}{0.4536}$



ROUND VACUUM CUPS WITH BALL VALVE AND SELF-LOCKING SUPPORT, FOR GLASS

Glass machinery manufacturers require increasingly accurate and safe clamping machines. This has led us to the creation of this series of cups.

The specially designed shape of this cup guarantees a firm grip. The other main feature is the utmost precision in the height, whose nominal size has a tolerance of only five hundredths of millimetre.

They are composed of:

- A sturdy aluminium support with a wide surface at the base limited by a seal whose purpose is to fix it to the bearing surface.
- A standard round flat cup which is cold-assembled onto the upper part of the support for gripping the load.
- A ball valve that opens up creating vacuum, only when activated by the load to be gripped.
- Two quick couplings for vacuum connection.

The detection of vacuum, for gripping and releasing the support from the bearing surface and for gripping and release of glass can be made via three-way vacuum valves or solenoid valves.

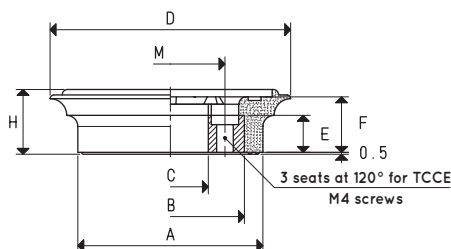

SPARE VACUUM CUP

Item	Force Kg	Volume cm ³	A Ø	B Ø	C Ø	D Ø	E	F	H	M Ø	Support material	Weight g
08 65 11 A	6.7	5.5	50	40	20.5	65	10	15	17.5	29.5	astælo	90

Compound: A = oil-resistant rubber

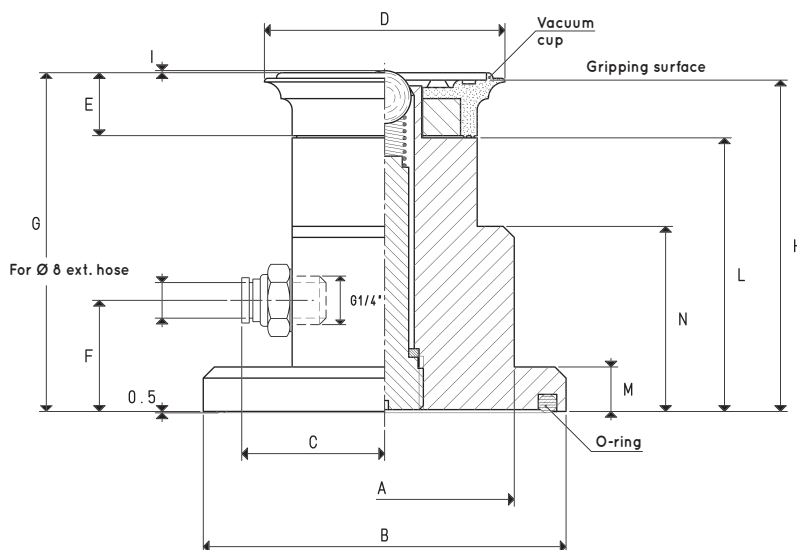

VACUUM CUP WITH BALL VALVE AND SELF-LOCKING SUPPORT

Item	Force Kg	A Ø	B Ø	C	D Ø	E	F	G	H	I	L	M	N	Vacuum cup item	O-ring item	Weight Kg
18 65 11/90 A	6.7	70	98	45	65	17.5	30	92.5	90	1	75	12	50	08 65 11 A	00 16 06	1.090

Compound: A = oil-resistant rubber

Note: The force of the vacuum cups indicated in the table represents 1/3 of the value of the theoretical force calculated at a level of vacuum of -75 KPa and a factor of safety 3.

Transformation ratio: N (newton) = Kg x 9.81 (force of gravity) inch = $\frac{\text{mm}}{25.4}$; pounds = $\frac{\text{g}}{453.6} = \frac{\text{Kg}}{0.4536}$