



## FLAT RECTANGULAR VACUUM CUPS WITH VULCANISED SUPPORT, FOR CLAMPING GLASS AND MARBLE

Glass and marble manufacturers' machining centres require increasingly accurate and safe clamping systems. This has led us to creating this new series of cups.

They are vulcanised onto a steel support and are provided with a hole in the centre for vacuum connection or for a ball valve, as well as with 2 holes on the internal circumference for housing Allen screws.

Their extremely flexible lip allows them to easily adapt to the sheets to be held, with no risk of deformation or rupture, even for the thinnest ones.

The particular shape of the internal support plane of these cups ensures a high friction coefficient with the gripping surface and especially a considerable grip on wet glass and marble sheets, thanks to the water drainage. All this guarantees a firm, safe grip. Furthermore, these cups feature the highest accuracy of their thickness, whose nominal height has a tolerance of only five hundredths of millimetre.

They are normally produced with oil-resistant rubber A, but they can be ordered in other compounds, listed on pg. 31, upon request and in minimum quantities to be defined in the order.



3D drawings are available on [vuototecnica.net](http://vuototecnica.net)

1

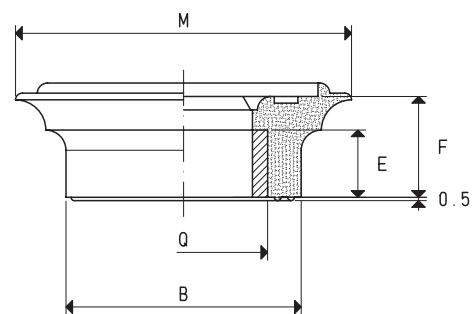
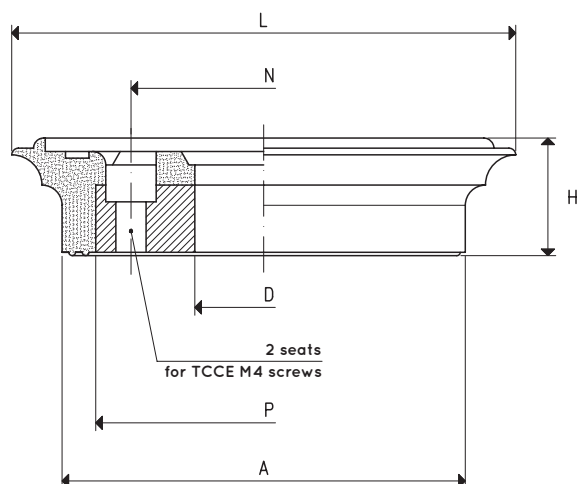

VACUUM CUP WITH VULCANISED SUPPORT

Item	Force Kg	Volume cm <sup>3</sup>	A	B	D Ø	E	F	H	L	M	N	P	Q	Support material	Weight g
08 50 75 A	7.5	6.1	60	35	20.5	10	15	17.5	75	50	39.5	50	25	steel	92

Compound: A = oil-resistant rubber

Note: The force of the vacuum cups indicated in the table represents 1/3 of the value of the theoretical force calculated at a level of vacuum of -75 KPa and a factor of safety 3.

Transformation ratio: N (newton) = Kg x 9.81 (force of gravity)      inch =  $\frac{\text{mm}}{25.4}$  ; pounds =  $\frac{\text{g}}{453.6} = \frac{\text{Kg}}{0.4536}$