



# FLAT ROUND VACUUM CUPS WITH VULCANISED SUPPORT

3D drawings are available on [vuototecnica.net](http://vuototecnica.net)

These cups have been designed for lifting and handling heavy loads, both vertically and horizontally. They are vulcanised onto a steel support and are provided with a central threaded hole for its fastening to the automation and with a side threaded hole for vacuum connection.

These cups have a labyrinth graved face made with the same compound as the cup, which allows gripping even the thinnest and most fragile glass and marble sheets, with no bending in the gripping area. The shape of its lip and the choice of the compound with which they are made ensure a firm grip on uneven and corrugated surfaces. The 08..40 series, along with sharing the same features, has an internal vertical lip which allows them to grip extremely rough surfaces, such as embossed or profiled metal sheets, sawn marble or granite, wooden boards, precast cement, etc.

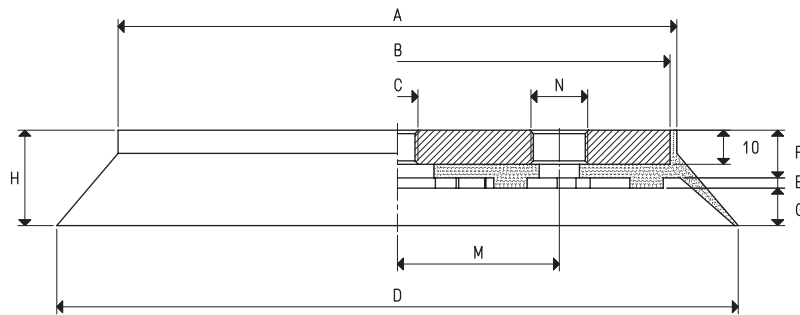

VACUUM CUPS WITH VULCANISED SUPPORT

Item	Force Kg	Volume cm <sup>3</sup>	A Ø	B Ø	C Ø	D Ø	E	F	G	H	M	N Ø	Support material	Weight Kg
<b>08 110 15 M8 *</b>	23.7	78.5	74	70	M8	110	2	14	10	26	26.0	G1/4"	steel	0.35
<b>08 110 15 *</b>	23.7	78.5	74	70	M12	110	2	14	10	26	26.0	G1/4"	steel	0.33
<b>08 150 15 *</b>	45.0	158.9	115	110	M12	150	2	14	10	26	40.0	G3/8"	steel	0.83
<b>08 200 10 *</b>	78.5	341.9	164	160	M12	200	3	14	11	28	47.5	G3/8"	steel	1.75
<b>08 250 10 *</b>	122.6	540.1	214	210	M12	250	3	14	11	28	72.5	G3/8"	steel	3.00
<b>08 300 10 *</b>	176.6	871.8	266	260	M16	300	5	15	11	31	89.0	G1/2"	steel	4.70
<b>08 350 10 *</b>	240.4	1210.1	316	310	M16	350	5	15	11	31	89.0	G1/2"	steel	6.60

\* Complete the code indicating the compound: A= oil-resistant rubber; N= natural para rubber; S= silicon

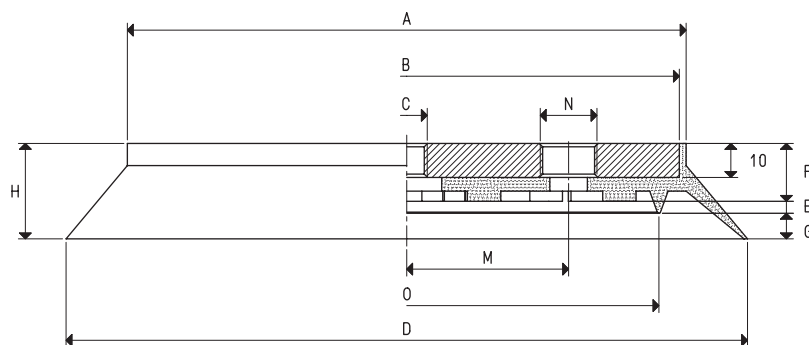

VACUUM CUPS WITH VULCANISED SUPPORT

Item	Force Kg	Volume cm <sup>3</sup>	A Ø	B Ø	C Ø	D Ø	E	F	G	H	M	N Ø	O Ø	Support material	Weight Kg
<b>08 110 40 M8*</b>	9.07	77.7	74	70	M8	110	3	16	7	26	26.0	G1/4"	68	steel	0.36
<b>08 110 40 *</b>	9.07	77.7	74	70	M12	110	3	16	7	26	26.0	G1/4"	68	steel	0.34
<b>08 150 40 *</b>	21.60	156.0	115	110	M12	150	3	16	7	26	40.0	G3/8"	105	steel	0.85
<b>08 200 40 *</b>	42.90	334.6	164	160	M12	200	3	17	8	28	47.5	G3/8"	148	steel	1.70
<b>08 250 40 *</b>	75.30	546.2	214	210	M12	250	3	17	8	28	72.5	G3/8"	196	steel	3.00
<b>08 300 40 *</b>	120.70	874.4	266	260	M16	300	3	18	10	31	89.0	G1/2"	248	steel	4.60
<b>08 350 40 *</b>	174.20	1219.4	316	310	M16	350	3	18	10	31	89.0	G1/2"	298	steel	6.50

\* Complete the code indicating the compound: A= oil-resistant rubber; N= natural para rubber; S= silicon

Note: The force of the vacuum cups indicated in the table represents 1/3 of the value of the theoretical force calculated at a level of vacuum of -75 KPa and a factor of safety 3.

Transformation ratio: N (newton) = Kg x 9.81 (force of gravity)

inch =  $\frac{\text{mm}}{25.4}$ ; pounds =  $\frac{\text{g}}{453.6} = \frac{\text{Kg}}{0.4536}$

Adapters for GAS - NPT threading available on page 1.130