

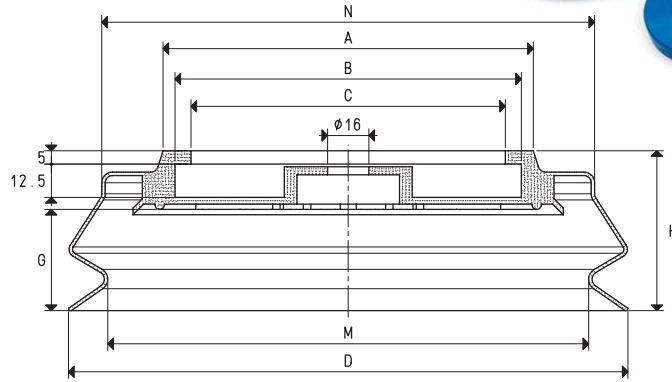

BELLOWS VACUUM CUPS FOR GLASS WITH SUPPORTS

This range of cups has been designed for vertically gripping stocked glass sheets. By laying the cup on the glass surface and opening the vacuum, the sheet will place itself orthogonally to the floor perfectly adhering to the cup internal face. The glass sheet can then be handled in any direction in full safety.

Their aluminium support has a central threaded hole for fastening it to the machine and for the vacuum connection. These cups can be cold fitted onto their supports without any adhesives.



VACUUM CUPS

Item	Force Kg	Volume cm ³	A Ø	B Ø	C Ø	D Ø	G	H	M Ø	N Ø	Bellows stroke mm
01 150 55 *	45.00	471.6	78	70	58	150	33	55	120	125	33
01 210 60 *	86.50	1220.6	138	130	118	210	38	61	180	185	38

* Complete the code indicating the compound: A= oil-resistant rubber; N= natural para rubber; S= silicon

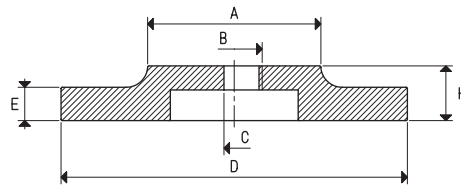

SUPPORTS

Item	A Ø	B Ø	C Ø	D Ø	E	H	Support material	For vacuum cup item	Weight g
00 08 280	35	G1/2"	--	70	12.5	22.5	aluminium	01 150 55	120
00 08 281	65	G1/2"	--	130	12.5	23.5	aluminium	01 210 60	465
00 08 286	35	---	8	70	12.5	22.5	aluminium	01 150 55	125
00 08 287	65	---	8	130	12.5	23.5	aluminium	01 210 60	470

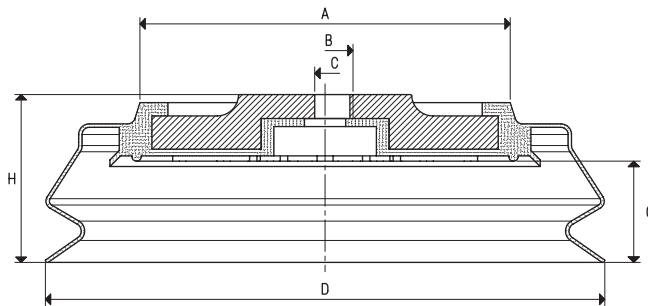

VACUUM CUPS WITH SUPPORT

Item	Force Kg	A Ø	B Ø	C Ø	D Ø	G	H	Vacuum cup item	Support item	Weight g
08 150 55 *	45.00	78	G1/2"	--	150	33	60	01 150 55	00 08 280	245
08 210 60 *	86.50	138	G1/2"	--	210	38	67	01 210 60	00 08 281	650
08 150 56 *	45.00	78	---	8	150	33	60	01 150 55	00 08 286	250
08 210 61 *	86.50	138	---	8	210	38	67	01 210 60	00 08 287	655

* Complete the code indicating the compound: A= oil-resistant rubber; N= natural para rubber; S= silicon

Note: The force of the vacuum cups indicated in the table represents 1/3 of the value of the theoretical force calculated at a level of vacuum of -75 KPa and a factor of safety 3.

Transformation ratio: N (newton) = Kg x 9.81 (force of gravity)

inch = $\frac{\text{mm}}{25.4}$; pounds = $\frac{\text{g}}{453.6} = \frac{\text{Kg}}{0.4536}$

Adapters for GAS - NPT threading available on page 1.130