

SUPPORTS FOR VACUUM CUPS

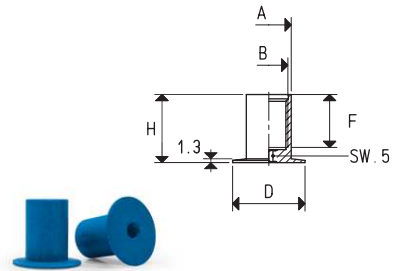

Item	A ∅	B ∅	D ∅	F	H	Support material	For vacuum cup item	Weight g
00 08 46	15.5	G1/4"	25	18	23.5	aluminium	01 85 10	6.5



Item	D ∅	E	F	G	H	Support material	For vacuum cup item	Weight g
00 08 50	9.5	17	13	10	27	aluminium	01 16 26 01 30 50 01 30 55 01 30 99 01 40 50	8.5

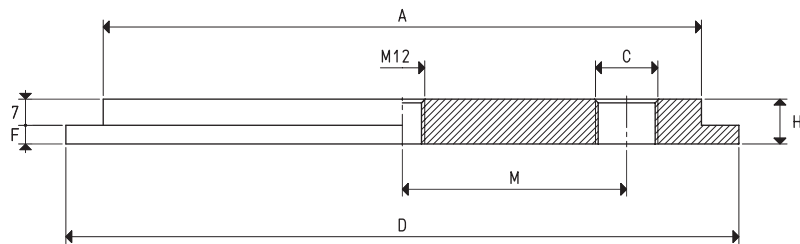
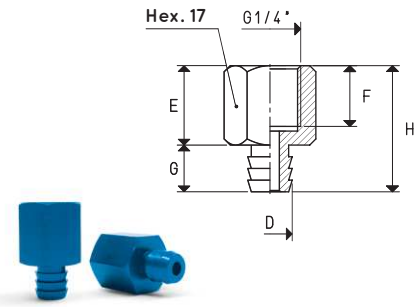

Item	A ∅	C ∅	D ∅	F	H	M	Support material	For vacuum cup item	Weight g
00 08 58	160	G3/8"	180	5	12	60	aluminium	01 180 15	740.0

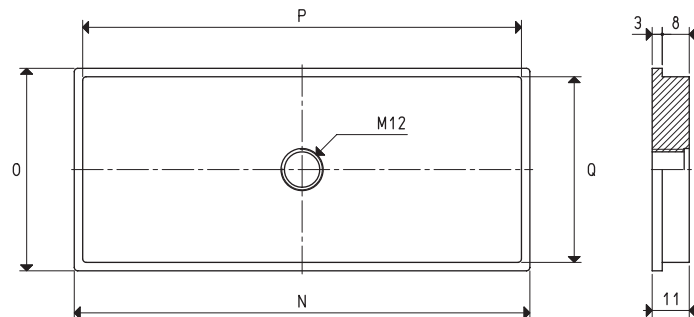

Item	N	O	P	Q	Support material	For vacuum cup item	Weight g
00 08 59	135	60	130	55	aluminium	01 135 60 01 150 75	218.4