

SUPPORTS FOR VACUUM CUPS

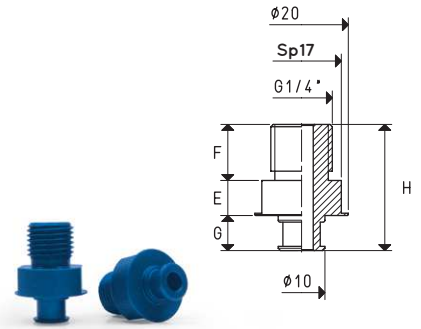

Item	E	F	G	H	Support material	For vacuum cup item	Weight g
00 08 135	7.5	12	7.5	27	aluminium	01 30 32	9.5
						01 40 42	
						01 43 28	



Item	E	F	G	H	Support material	For vacuum cup item	Weight g
00 08 136	12	14	8	37.3	aluminium	01 85 10	9.2

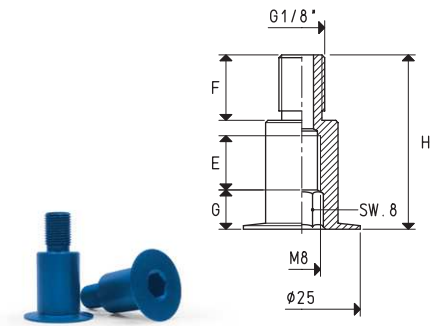

Item	E	F	G	H	Support material	For vacuum cup item	Weight g
00 08 141	14	10	9.5	23.5	aluminium	01 50 53	19.7
						01 53 35	

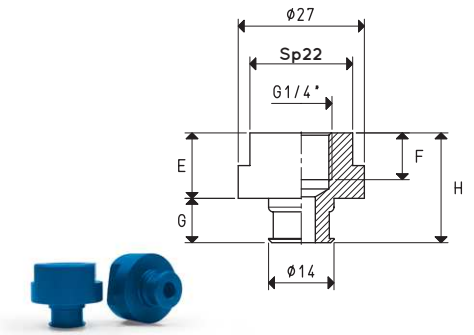

Item	E	F	G	H	Support material	For vacuum cup item	Weight g
00 08 142	7.5	12	9.5	29	aluminium	01 50 53	15.7
						01 53 35	

