

VACUPREDATOR VACUUM CUPS FOR GRIPPING BAGS, PACKS AND FLEXIBLE CONTAINERS



For the gripping of bags, packs and flexible containers in paper or plastic, containing powders, granulated products, loose or liquid products. These new vacuum cups have been designed and manufactured to safely grip even the most difficult and irregular packages. Made of anodised aluminium and equipped with a slotted plate inside them to allow flexible containers to perfectly adapt to the cup, as well as a special foam rubber seal which, following the inevitable creases that form on flexible containers during gripping, prevents perimeter vacuum losses.

They are especially suitable for gripping flow packs, flexible containers for intravenous therapy, bags of sweets or other similar products, plastic bags of granulated products, of cement, sugar or flour, etc.

The lifting force was calculated considering a level of vacuum of at least -75 Kpa, the total surface enclosed within the seal and a factor of safety 3.

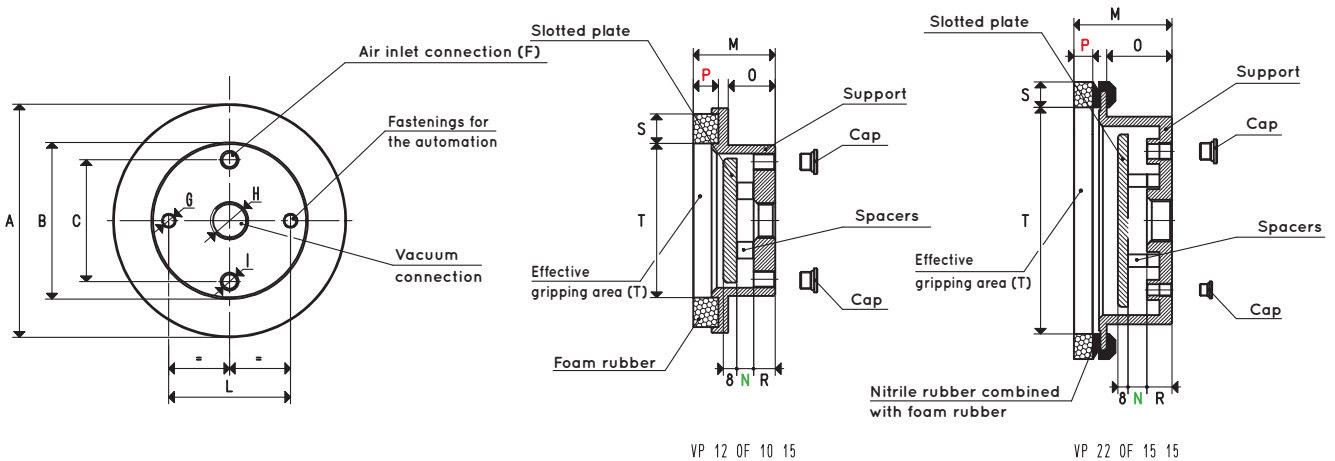

ROUND VACUPREDATOR VACUUM CUPS

Item	Force Kg	A Ø	B Ø	C	F Ø	G Ø	H Ø	I Ø	L	M	N	O	P	R	S	T Ø	Weight Kg
VP 12 OF 10 15	17.5	134	89	70	G1/8"	M8	G1/2"	G1/8"	70	49	10	28	15	13	17.5	92	0.54
VP 22 OF 15 15	63.6	220	165	110	G1/4"	M12	G1"	G1/8"	120	78	15	52	15	20	20.0	180	1.55

Note: The force of the vacuum cups indicated in the table represents 1/3 of the value of the theoretical force calculated at a level of vacuum of -75 KPa and a factor of safety 3.

Transformation ratio: N (newton) = Kg x 9.81 (force of gravity)

inch = $\frac{\text{mm}}{25.4}$; pounds = $\frac{\text{g}}{453.6} = \frac{\text{Kg}}{0.4536}$

Adapters for GAS - NPT threading available on page 1.130