



# SUPPORTS FOR VACUUM CUPS

3D drawings are available on [vuotecnica.net](http://vuotecnica.net)

1

Item	D ∅	E	F	G	H	Support material	For vacuum cup item	Weight g
<b>00 08 24</b>	12	8	14	12	34	aluminium	01 50 20 01 65 28	10.3

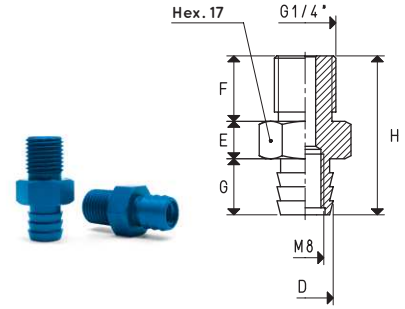

Item	D ∅	E	F	G	H	Support material	For vacuum cup item	Weight g
<b>00 08 26</b>	14.5	8	14	13.5	35.5	aluminium	01 52 50	13.5

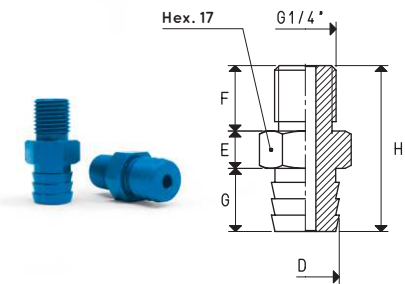

Item	D ∅	E	F	G	H	Support material	For vacuum cup item	Weight g
<b>00 08 28</b>	25	12	14	8	37.3	aluminium	01 85 10	13.4

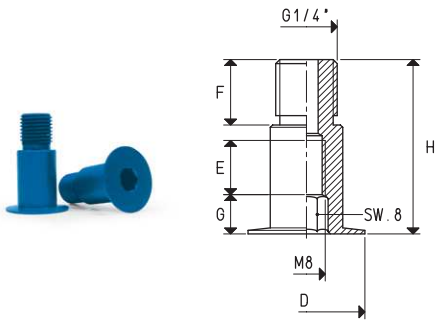

Item	A ∅	B ∅	D ∅	F	H	Support material	For vacuum cup item	Weight g
<b>00 08 29</b>	15.5	M12	25	18	23.5	aluminium	01 85 10	6.6

