



DIRECT DRIVE 2-WAY VACUUM SOLENOID VALVES

These state of the art solenoid valves feature minimal overall dimensions and high volumetric efficiency and high response speed at any level of vacuum. They are the result of an attentive choice of materials, state of the art constructive techniques and of the in-depth knowledge of our technicians. This series of solenoid valves is patented.

The DDN solenoid valves are direct drive, two-way, two-position valves with direct drive, double shutter and they are normally closed.

They are composed of hot pressed brass body where the connections are located, an internal mechanism with double shutter and of an actuator activated by an electric coil.

The standard electric coil is fully plasticised with synthetic resin, tight execution, insulation class F (up to 155°C) compliant with VDE standards, with 6.3 mm three-terminal electrical connections in compliance with EN 175301-803 (ex DIN 43650). Protection degree IP 54; IP 65 with connector inserted. Tolerance permitted on the nominal voltage value: $\pm 10\%$.

Maximum absorption: 20 V.A. with AC and 18 W with DC. (except for DDN 25 which cannot be activated with DC).

The electric coil can be rotated 360°. The connector can be rotated 180° on the coil and can be supplied, upon request, with LED lights, anti-interference circuit and/or with protection devices against overvoltage and polarity reversal. For correct operation, we recommend installing the solenoid valve upside-down.

DDN solenoid valves are particularly indicated for degassers, autoclaves, vacuum thermo-welders and in all applications where suction has to be controlled separately from the air inlet into circuit.

Technical features

Operating pressure: from 0.5 to 1500 absolute mbar

Temperature of suctioned fluid: from -5 to +60°C

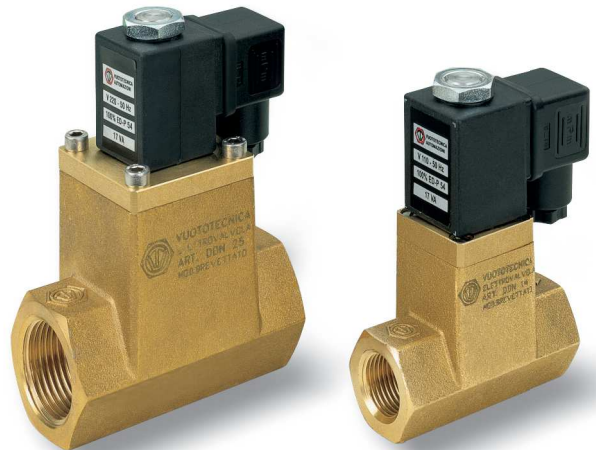

3D drawings are available on vuototecnica.net

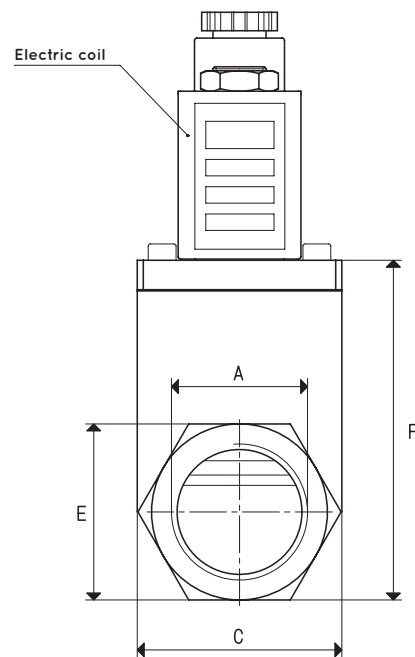
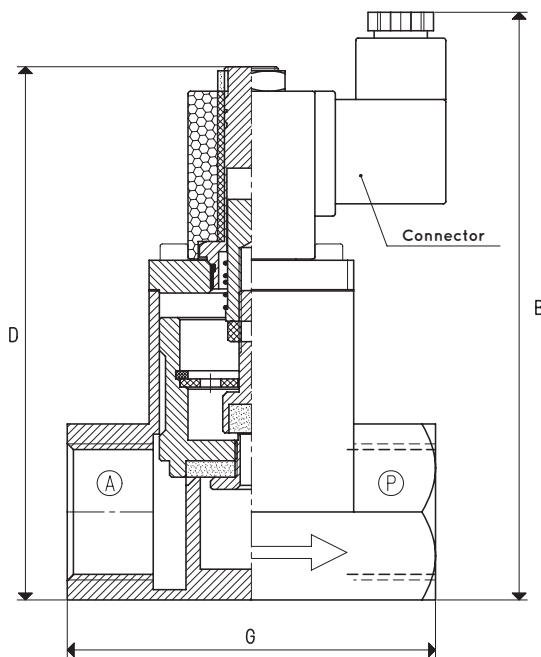

2 / 2 NC

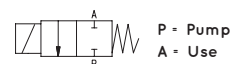

Item	A Ø	Max flow rate m³/h	Level of vacuum abs. mbar		Reaction time msec		Mouth Ø	Cross-section of passage mm²	B	C	D	E	F	G	Weight Kg
			min	max	energ.	de-energ.									
DDN 14	G1/2"	20	1000	0.5	30	15	14	154	127	35	110	30	63	75	0.83
DDN 25	G1"	90	1000	0.5	55	33	25	490	142	50	128	43	82	90	1.56

Note: The coil and the connector are not integral parts of the solenoid pilot valve and, therefore, must be ordered separately (See accessories for solenoid valves).

Transformation ratio: N (newton) = Kg x 9.81 (force of gravity)

inch = $\frac{\text{mm}}{25.4}$; pounds = $\frac{\text{g}}{453.6} = \frac{\text{Kg}}{0.4536}$

Adapters for GAS - NPT threading available on page 1.130