

PLUNGER VALVES

Plunger valves are composed of a natural colour or chrome-plated cylindrical brass body, depending on the items, of a steel plunger with a conical valve, a thrust spring, a nylon disc whose task is to thrust the spring onto a larger contact surface, thus avoiding unsightly prints on the load to be gripped.

Connected to vacuum, they are normally closed.

They activate suction, thus creating a vacuum, only when the plunger is in contact with the gripping surface.

They are also available in various versions, all suitable for our vacuum cups.

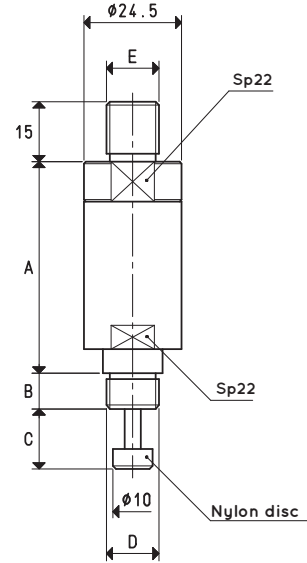

Item	A	B	C	D Ø	E Ø	Weight g	Vacuum cup item
19 01 10	53	9	15.0	G1/4"	G1/4"	160	08 150 16
19 01 11	53	9	16.0	M12	G1/4"	166	08 80 20
19 01 12	53	9	22.0	M12	G1/4"	152	08 127 15

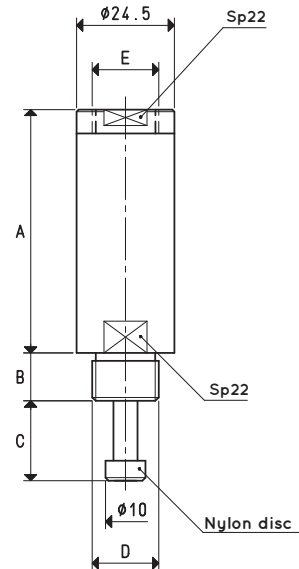

Item	A	B	C	D Ø	E Ø	Weight g	Vacuum cup item
19 02 10	61.5	12	22.0	G3/8"	G3/8"	164	08 150 15 08 200 10 08 250 10
19 03 10	61.0	10	22.5	G1/2"	G3/8"	172	08 300 10 08 350 10
19 04 10	68.5	11	42.0	G1/2"	G3/8"	182	08 360 10