



CHECK VALVES

These one-way valves are made with bronze and brass with a seal in NBR nitrile rubber or, upon request, in Viton®, only for series 10 ... 11. To ensure a practical assembly they are available in two versions: horizontal and vertical.

Fitted on the vacuum pump suction inlet, as soon as the latter stop, these valves prevent the air from returning in the plant (piping, tanks, autoclaves, vacuum gripping systems, vacuum cups, etc.), guaranteeing a perfect seal and preventing the oil from returning into the pump stator, which would cause considerable damages.

Therefore, check valves are mandatory on all vacuum pumps with lubrication that do not have them built-in.



HORIZONTAL

Item	R Ø	Sp	H	L	Weight Kg
10 02 10	G3/8"	27	49	43	0.19
10 03 10	G1/2"	27	49	43	0.17
10 04 10	G3/4"	34	58	52	0.27
10 05 10	G1"	42	66	62	0.43
10 06 10	G1" 1/4	50	75	72	0.59
10 07 10	G1" 1/2	57	86	80	0.79
10 08 10	G2"	69	99	94	1.08

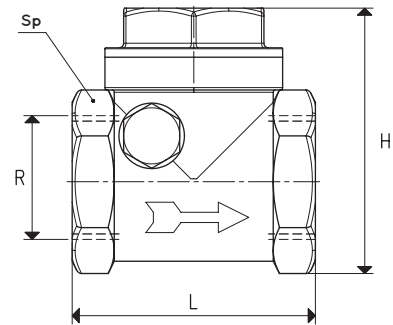

4



VERTICAL

Item	R Ø	Sp	D Ø	H	Weight Kg
10 01 11	G1/4"	21	28	47	0.10
10 02 11	G3/8"	25	35	59	0.17
10 03 11	G1/2"	26	35	58	0.12
10 04 11	G3/4"	33	42	65	0.28
10 05 11	G1"	40	48	74	0.42
10 06 11	G1" 1/4	50	61	82	0.64
10 07 11	G1" 1/2	55	71	92	0.87
10 08 11	G2"	70	87	100	2.70

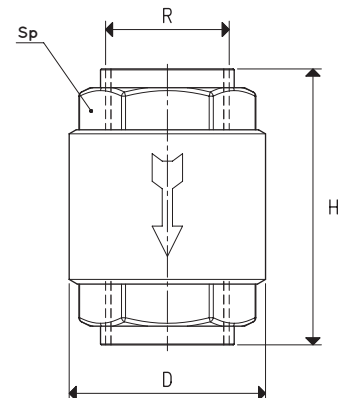

Note: To order valves with seals in Viton®, add the letter V to the item (example: 10 02 11 V)

Transformation ratio: N (newton) = Kg x 9.81 (force of gravity)

inch = $\frac{\text{mm}}{25.4}$; pounds = $\frac{\text{g}}{453.6} = \frac{\text{Kg}}{0.4536}$

Adapters for GAS - NPT threading available on page 1.130