

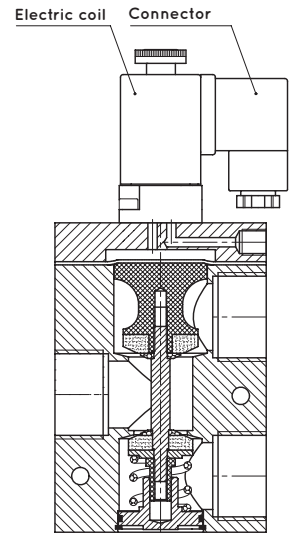

SERVO-CONTROLLED 3-WAY VACUUM SOLENOID VALVES

3D drawings are available on vuototecnica.net

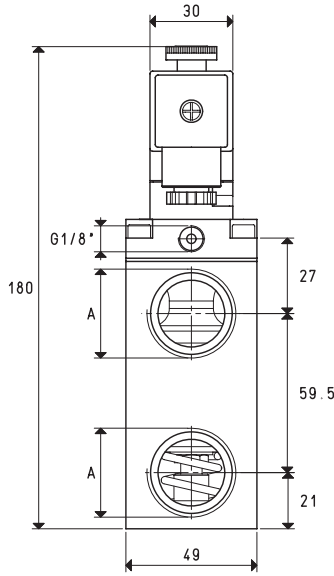
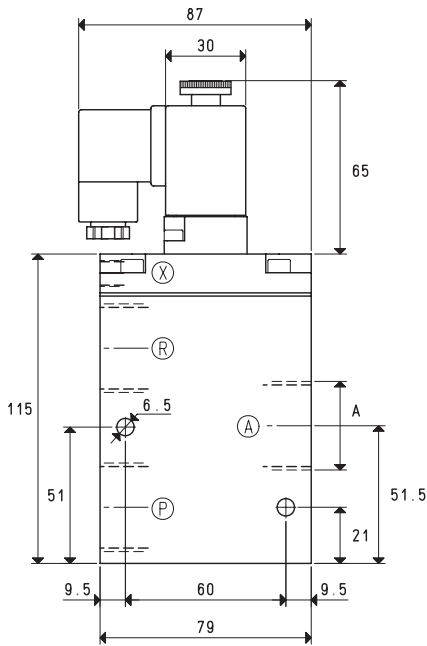

4

NC

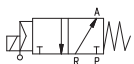

X = Compressed air supply
P = Pump
A = Use
R = Discharge

NO

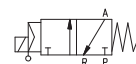

X = Compressed air supply
P = Discharge
A = Use
R = Pump

Item	A Ø	Max flow rate m ³ /h	Level of vacuum abs. mbar		Reaction time msec		Mouth Ø	Cross-section of passage mm ²	Pressure at servo-controlled *bar	Weight Kg
			min	max	energ.	de-energ.				
07 04 11	G3/4"	40	1000	0.5	16	40	20	314	6 ÷ 8	1.25
07 05 11	G1"	90	1000	0.5	18	42	25	490	6 ÷ 8	1.16

* Add the letters LP to the item for servo-controlled pressures 4 - 6 bar.

Note: The coil and the connector are not integral parts of the solenoid valve and, therefore, must be ordered separately (See accessories for solenoid valves).

Solenoid valve servo-controlled power must be supplied with non-lubricated compressed air, 5 micron filtration, according to standard ISO 8573-1 class 4.

Transformation ratio: N (newton) = Kg x 9.81 (force of gravity)

inch = $\frac{\text{mm}}{25.4}$; pounds = $\frac{\text{g}}{453.6} = \frac{\text{Kg}}{0.4536}$

Adapters for GAS - NPT threading available on page 1.130