



DIRECT DRIVE 3-WAY VACUUM SOLENOID VALVES WITH BISTABLE IMPULSE SOLENOID PILOT VALVE AND WITH LOW ABSORPTION ELECTRIC COIL

3D drawings are available on vuototecnica.net

These solenoid valves have the same function and the same structure as the previously described three-way valves. Even their structure is the same; what differentiates them are the bistable impulse pilot valve powered by a low absorption fitted electrical coil which, with a simple electrical impulse, exchanges the shutter positions and keeps them there even in absence of electricity, until it receives a new impulse of opposite polarity. For this reason, they can only be supplied with direct current electric coils. Their use is especially recommended in all those cases requiring maximum connection security at the vacuum source, even in the absence of electrical power supply. The electric coils of the solenoid pilot valve are fully plastic-coated in synthetic resin, watertight, insulation class F (up to 155°C) as per standard VDE, with 3 mm two-terminal electrical connections for connectors in compliance with EN 175301-803 (ex DIN 43650) - C. Protection degree IP 54; IP 65 with connector inserted. Available for voltages 12-24VDC. Tolerance permitted on the nominal voltage value: ±10%. Maximum electric power: 1 W. The connector can be rotated 180° on the coil and can be supplied, upon request, with LED lights, anti-interference circuit and/or with protection devices against overvoltage and polarity reversal. The push-button device for their manual activation cannot be installed on these solenoid valves.

Technical features
 Operating pressure: from 0.5 to 850 absolute mbar
 Temperature of suctioned fluid: from -5 to +60°C



4

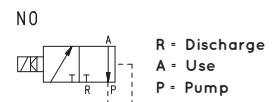
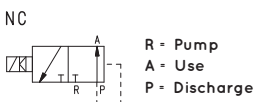
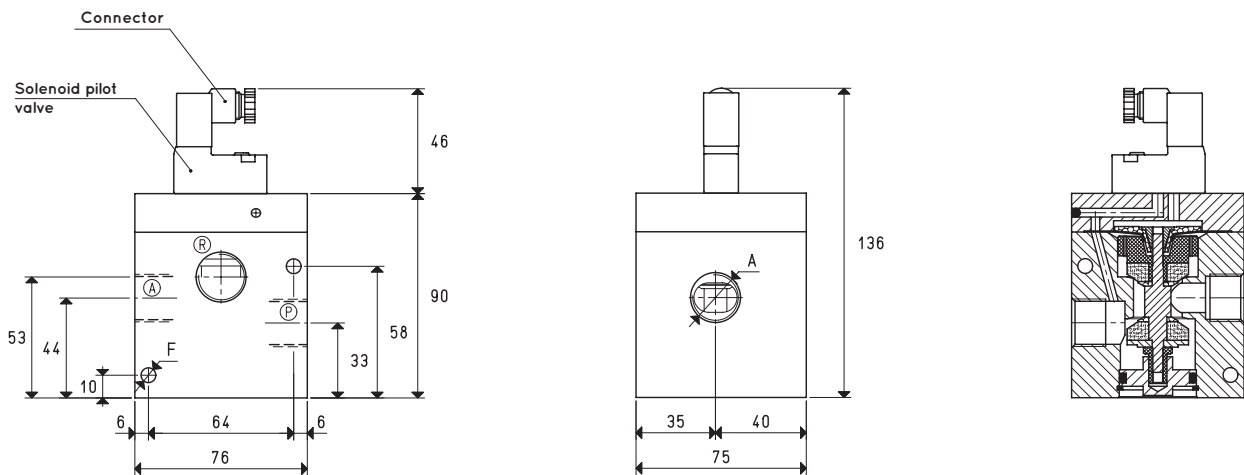

Item	A	Max flow rate	Level of vacuum		Reaction time		Mouth	Cross-section of passage	F	Weight
			abs. mbar	min	max	msec				
07 03 63 NC	G1/2"	20	850	0.5	33	17	15	176	6.5	1.35
07 03 63 NO					22	20				
07 04 63 NC	G3/4"	40	850	0.5	33	17	20	314	6.5	1.30
07 04 63 NO					22	20				

Note: Specify the voltage of the electric coil when ordering. (Example: 07 03 63 NC V24-CC)

The connector is not integral parts of the solenoid valve and, therefore, must be ordered separately (See accessories for solenoid valves).

Transformation ratio: N (newton) = Kg x 9.81 (force of gravity)

inch = $\frac{\text{mm}}{25.4}$; pounds = $\frac{\text{g}}{453.6} = \frac{\text{Kg}}{0.4536}$

Adapters for GAS - NPT threading available on page 1.130