

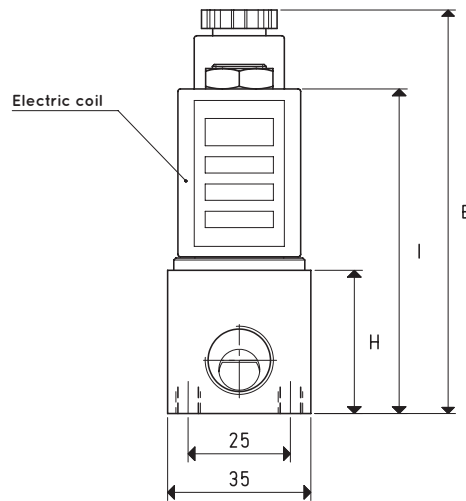

3-WAY VACUUM SOLENOID PILOT VALVES

3D drawings are available on vuototecnica.net

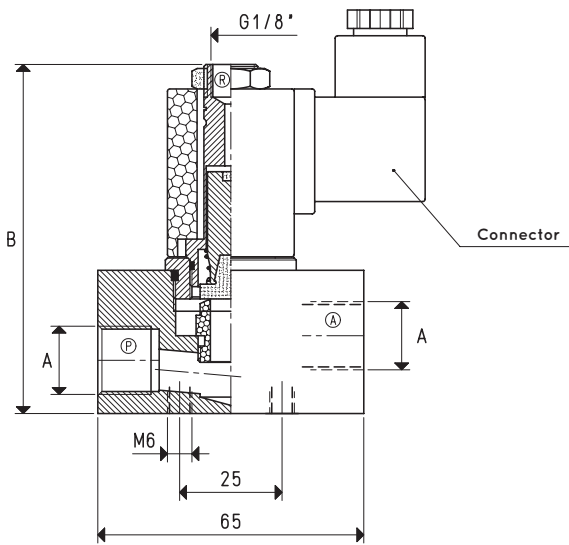

4

3 / 2 NC

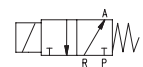

P = Pump
A = Use
R = Discharge

3-WAY SOLENOID PILOT VALVES

Item	A Ø	Max flow rate m ³ /h	Level of vacuum abs. mbar		Reaction time msec		Mouth Ø	Cross-section of passage mm ²	B	E	H	I	Weight g
			min	max	energ.	de-energ.							
07 02 16	G3/8"	8	1000	0.5	22	10	10	78.5	85	98	35	79	392
07 03 16	G1/2"	10	1000	0.5	28	10	12	113.0	85	98	35	79	377

Note: The coil and the connector are not integral parts of the solenoid pilot valve and, therefore, must be ordered separately (See accessories for solenoid valves).

Transformation ratio: N (newton) = Kg x 9.81 (force of gravity)

inch = $\frac{\text{mm}}{25.4}$; pounds = $\frac{\text{g}}{453.6} = \frac{\text{Kg}}{0.4536}$

Adapters for GAS - NPT threading available on page 1.130