



SERVO-CONTROLLED 3-WAY VACUUM SOLENOID VALVES

3D drawings are available on vuototecnica.net

The three-way vacuum solenoid valves in this series are two-position valves with pneumatically servo-controlled conical shutters. They can be used normally either closed or open. They are composed of an anodised aluminium body, two Vulkollan® shutters assembled onto a stainless steel stem, a membrane for servo-control made with special compounds and a thrust spring for the shutter return; an actuator activated by an electric coil managed the compressed air supply. These valves allow reducing frictions and internal dynamic stresses to the minimum. The result being a high response speed and a guarantee of long lasting duration. The standard electric coil is fully plasticised with synthetic resin, tight execution, insulation class F (up to 155°C) compliant with VDE standards, with 6.3 mm three-terminal electrical connections in compliance with EN 175301-803 (ex DIN 43650). Protection degree IP 54; IP 65 with connector inserted. Tolerance permitted on the nominal voltage value: ±10%. Maximum absorption: 20 V.A. with AC and 18 W with DC. The electric coil can be rotated 360°. The connector can be rotated 180° on the coil and can be supplied, upon request, with LED lights, anti-interference circuit and/or with protection devices against overvoltage and polarity reversal. The three-way vacuum solenoid valves are used for vacuum interception on power supply units and suction palletisers, robots, feeders, bag opening units and in all those cases where rapid exchange between pump suction for vacuums and air supply into the circuit is necessary for quick restoration of atmospheric pressure. They can be supplied upon request with an SM device for manually opening and closing the solenoid valves already installed.



Technical features

Operating pressure: from 0.5 to 3000 absolute mbar

Servo-control pressure: see table

Temperature of suctioned fluid: from -5 to +60°C

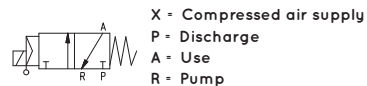
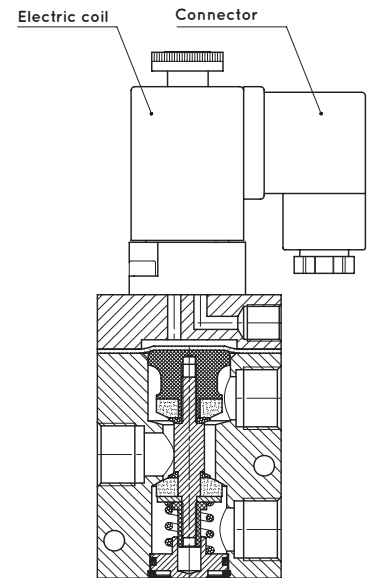
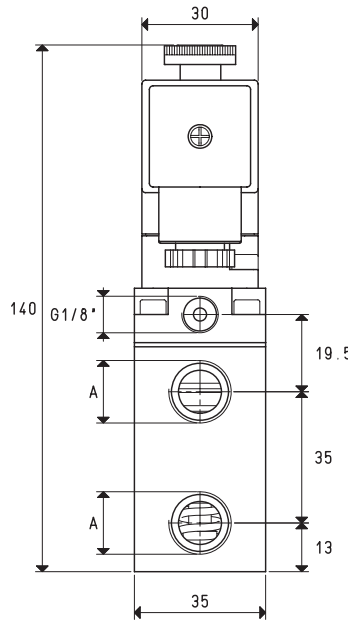
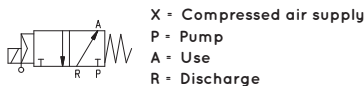
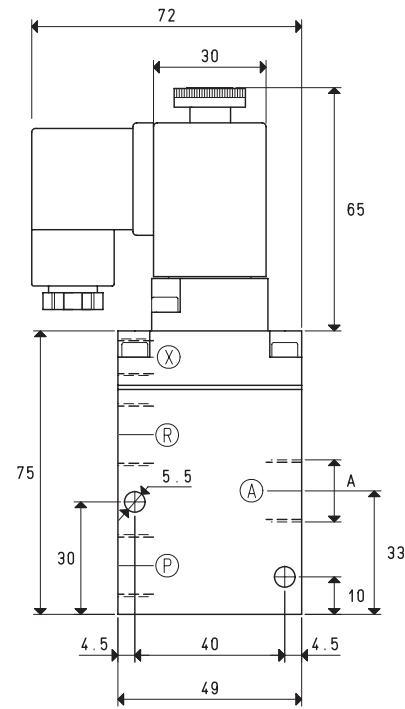

Item	A Ø	Max flow rate m³/h	Level of vacuum abs. mbar		Reaction time msec		Mouth Ø	Cross-section of passage mm²	Pressure at servo-controlled *bar	Weight Kg
			min	max	energ.	de-energ.				
07 01 11	G1/4"	6	1000	0.5	16	27	8.5	56.8	4 ÷ 7	0.56
07 02 11	G3/8"	10	1000	0.5	16	27	11.5	103.8	4 ÷ 7	0.54

Note: The coil and the connector are not integral parts of the solenoid valve and, therefore, must be ordered separately (See accessories for solenoid valves).

Solenoid valve servo-controlled power must be supplied with non-lubricated compressed air, 5 micron filtration, according to standard ISO 8573-1 class 4.

Transformation ratio: N (newton) = Kg x 9.81 (force of gravity)

inch = $\frac{\text{mm}}{25.4}$; pounds = $\frac{\text{g}}{453.6} = \frac{\text{Kg}}{0.4536}$

Adapters for GAS - NPT threading available on page 1.130