



Connectors are fundamental for bringing electric current to the solenoid valve coils.

They are available in the simple plug version installed as standard and, upon request, with LEDs to signal the presence of voltage, with anti-interference circuits, protection devices against overvoltage and polarity reversal.

When correctly installed, all connectors provide full protection against water jets, according to EN 60529 standards (protection class IP 65).

Moreover, they meet VDE 0110-1/89 standards, working voltage up to 250 V, overvoltage category II, Degree of use 3, regarding insulation class.

In all contacts, a snap joint between contact holders and the external protection guarantees a safe locking and easy assembly.

Safe locking is essential for guaranteeing the operator full protection when handling the connector. The contact holder can be easily extracted from its casing simply using a screwdriver. This operation also allows orienting the earthing contact in the desired direction.

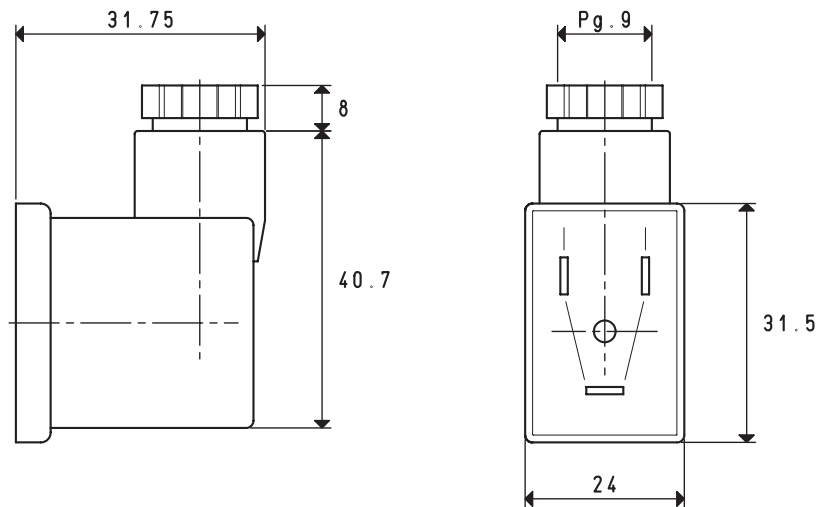

CONNECTORS FOR COILS

Item	Nominal flow rate of contacts A	Max cross-section of conductors mm ²	Temperature in operation °C	Ø cable mm	Weight g	Notes	For coils item
00 07 174	max 16	1.5	-40 ÷ +90	6 ÷ 8	24	Standard	00 07 172
00 07 260	max 16	1.5	-40 ÷ +90	6 ÷ 8	24	With LED	00 07 173

Transformation ratio: N (newton) = Kg x 9.81 (force of gravity)

inch = $\frac{\text{mm}}{25.4}$; pounds = $\frac{\text{g}}{453.6} = \frac{\text{Kg}}{0.4536}$