

CONVEYOR VACUUM GENERATOR PVR 25 MS, WITH SUPPORT FOR FASTENING TO VACUUM CUPS

The particular shape of this rectilinear flow vacuum generator allows for the supply of vacuum cups, especially in the presence of abundant quantities of dust, liquids, sawdust, of various origins, and shavings, without interference. It can reach a level of vacuum of -70KPa, a suction flow rate of about 10 m³/h, with a supply pressure of 3 bar.

The support it is equipped with allows it to be fixed to flat vacuum cups, starting from Ø 200 mm, while a special adapter, available upon request, allows the generator to be fixed at a distance. A "free-flow" silencer is installed on the intake air exhaust with high sound reduction, equipped with appropriate safety protection to prevent the dispersion of the sucked solid impurities in the work environment.

Also upon request, it is possible to supply a digital micro vacuum switch, item 12 05 11 P, for checking the level of vacuum inside the vacuum cup, and a vacuum gauge item 09 03 15, for direct reading of the level.

A good filtration of the compressed air supply will be sufficient to make these devices fully maintenance-free. Their use is recommended in particular on vacuum cups for gripping marble and granite, bricks, rusty metal sheets, rough wooden boards and anything else with especially dirty gripping surfaces.

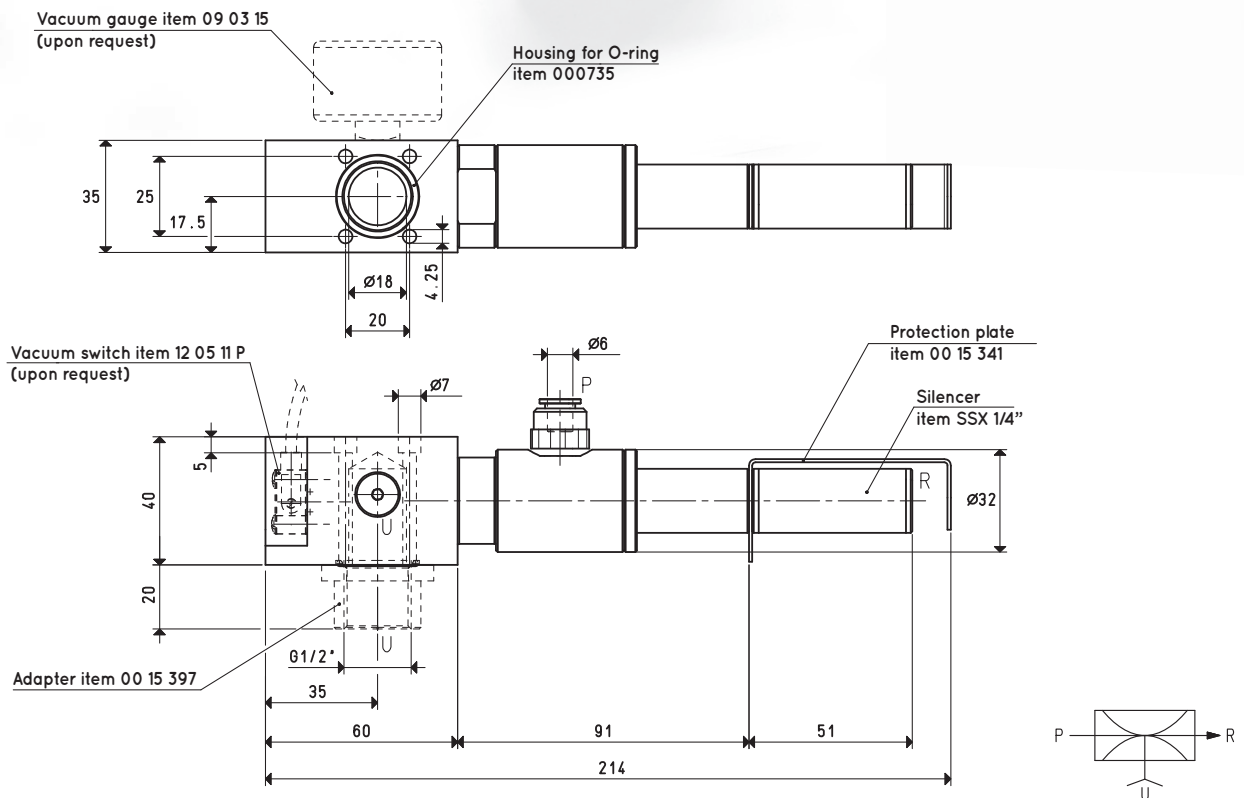
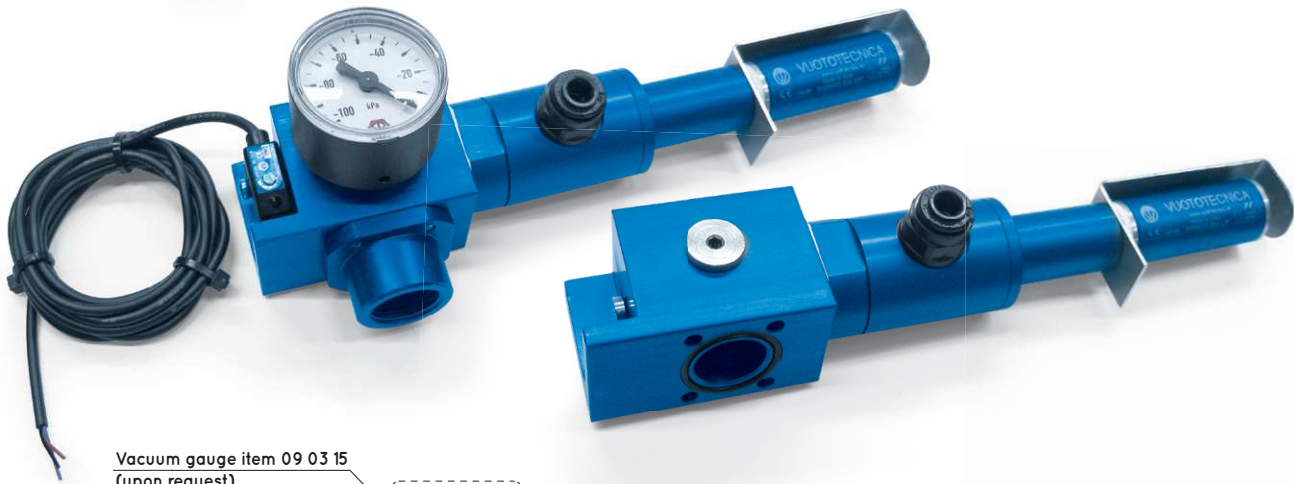

Item		PVR 25 MS		
Intake air flow rate	m ³ /h	6.4	9.4	9.6
Maximum level of vacuum	-KPa	12	45	70
Final pressure	abs. mbar	880	550	300
Supply pressure	bar	1	2	3
Air consumption	NI/s	8.2	10.87	12.49

Note: All vacuum values indicated in the table are valid at the normal atmospheric pressure of 1013 mbar and obtained with a constant supply pressure.

Vacuum generator supply must be carried out with non-lubricated compressed air, 5 micron filtration, in accordance with standard ISO 8573-1 class 4.

Transformation ratio: N (newton) = Kg x 9.81 (force of gravity)

inch = $\frac{\text{mm}}{25.4}$; pounds = $\frac{\text{g}}{453.6} = \frac{\text{Kg}}{0.4536}$

Adapters for GAS - NPT threading available on page 1.130