



## CARTRIDGE VACUUM GENERATOR PVR 3 OT

Also the construction of this cartridge vacuum generator was necessary in order to meet the demand for ever smaller and more performing devices in the packaging sector.

The compressed air supply pressure is between 1 and 3 bar, while the maximum level of vacuum is -52 KPa, with a flow rate of 2.6 m<sup>3</sup>/h.

Also the shape of these generators, like the previous ones described, allows for the suction of dust and small processing waste without clogging problems.

They are made of brass as standard, but upon request they can also be supplied in different metals.

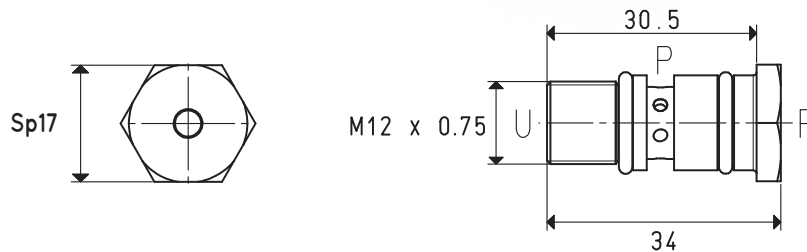

### CREATION OF HOUSING FOR CARTRIDGE INSERTION

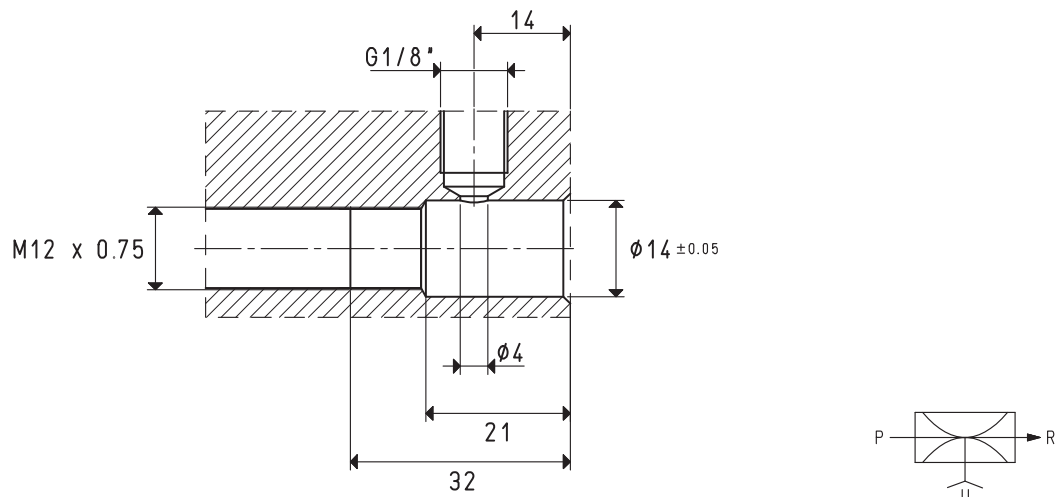

Item	PVR 3 OT					
Intake air flow rate	m <sup>3</sup> /h	2.2	2.6	2.6	2	1.6
Maximum level of vacuum	-KPa	21	37	52	50	47
Final pressure	abs. mbar	790	630	480	500	530
Supply pressure	bar	1	2	3	4	5
Air consumption	Nl/s	1.25	1.8	2.4	3.1	3.6
Temperature of use	°C	-10 / +60				
Noise level	dB(A)	78				
Weight	g	60				

Note: All vacuum values indicated in the table are valid at the normal atmospheric pressure of 1013 mbar and obtained with a constant supply pressure.

Vacuum generator supply must be carried out with non-lubricated compressed air, 5 micron filtration, in accordance with standard ISO 8573-1 class 4.