

MULTI-STAGE AND MODULAR VACUUM GENERATORS PVP 450 and PVP 600 MD / MDLP

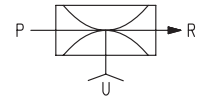
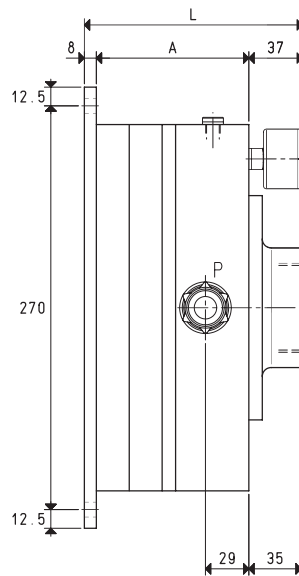
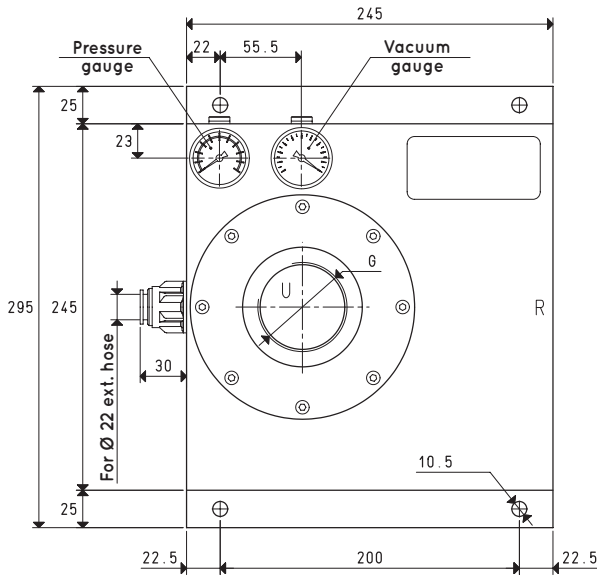

3D drawings are available on vuotecnica.net

P=COMPRESSED AIR CONNECTION R=EXHAUST U=VACUUM CONNECTION

Item		PVP 450 MD			PVP 600 MD		
Intake air flow rate	m ³ /h	490	530	580	640	700	750
Maximum level of vacuum	-KPa	65	82	90	65	82	90
Final pressure	abs. mbar	350	180	100	350	180	100
Supply pressure	bar	4	5	6	4	5	6
Optimal supply pressure	bar			6			6
Air consumption	NI/s	35.4	40.6	47.8	45.4	56.8	63.2
Temperature of use	°C			-20 / +100			-20 / +100
Noise level at optimal supply pressure	dB(A)			74			78
Weight	Kg			9.1			10.3
A				122			142
G	Ø			G2" 1/2			G3"
L				167			187

Item		PVP 450 MDLP			PVP 600 MDLP		
Intake air flow rate	m ³ /h	250	440	500	330	590	670
Maximum level of vacuum	-KPa	30	64	88	30	64	88
Final pressure	abs. mbar	700	360	120	700	360	120
Supply pressure	bar	1	2	3	1	2	3
Optimal supply pressure	bar			3			3
Air consumption	NI/s	32.0	48.8	65.8	42.0	66.0	87.7
Temperature of use	°C			-20 / +100			-20 / +100
Noise level at optimal supply pressure	dB(A)			80			82
Weight	Kg			9.1			10.3
A				122			142
G	Ø			G2" 1/2			G3"
L				167			187

Spare parts		PVP 450 MD / MDLP		PVP 600 MD / MDLP	
Sealing kit and reed valves	item	00 KIT PVP 450 MD		00 KIT PVP 600 MD	
Exhaust silencer	item	00 15 70		00 15 70	
Silencer on nozzles	item	00 15 71 + 00 15 72		N°2 00 15 72	
Vacuum gauge	item	09 03 15		09 03 15	
Pressure gauge	item	09 03 25		09 03 25	

Note: All vacuum values indicated in the table are valid at the normal atmospheric pressure of 1013 mbar and obtained with a constant supply pressure.

Add the letter R to the item for a generator supplied with an integrated check valve (Example: PVP 450 MDR).

Vacuum generator supply must be carried out with non-lubricated compressed air, 5 micron filtration, in accordance with standard ISO 8573-1 class 4.

Transformation ratio: N (newton) = Kg x 9.81 (force of gravity)

inch = $\frac{\text{mm}}{25.4}$; pounds = $\frac{\text{g}}{453.6} = \frac{\text{Kg}}{0.4536}$

Adapters for GAS - NPT threading available on page 1.130



Air flow rate (NI/s) at different levels of vacuums (-KPa) at optimal supply pressure

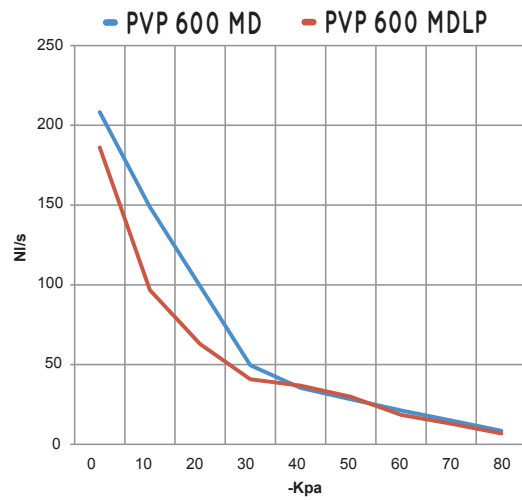
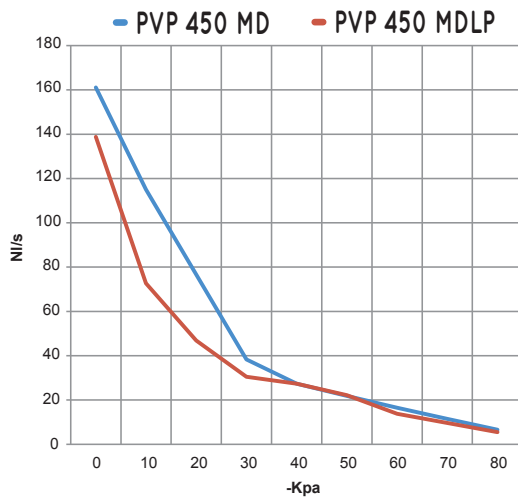

Generator item	Supp. press. bar	Air consumption NI/s	Air flow rate (NI/s) at different levels of vacuums (-KPa) at optimal supply pressure										Max vacuum -KPa
			0	10	20	30	40	50	60	70	80		
PVP 450 MD	6.0	47.8	161.1	115.0	76.7	38.3	27.4	21.9	16.5	11.5	6.6	90	
PVP 600 MD	6.0	63.2	208.3	148.8	99.2	49.6	35.4	28.3	21.3	14.9	8.5	90	
PVP 450 MDLP	3.0	65.8	138.8	72.7	46.9	30.5	27.4	22.2	13.8	9.6	5.5	88	
PVP 600 MDLP	3.0	87.7	186.1	96.7	62.9	40.8	36.8	29.8	18.5	12.9	6.8	88	

Evacuation rates (ms/l = s/m³) at different levels of vacuums (-KPa) at optimal supply pressure

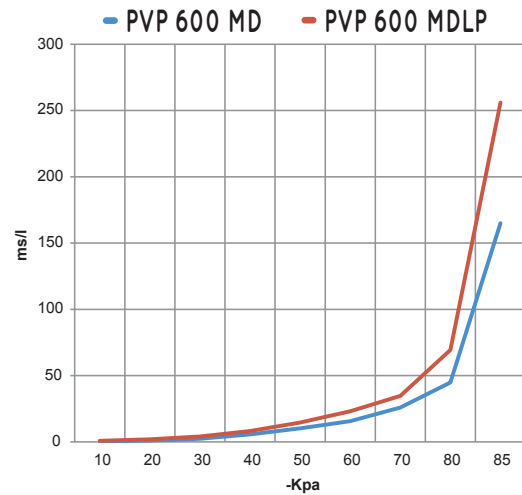
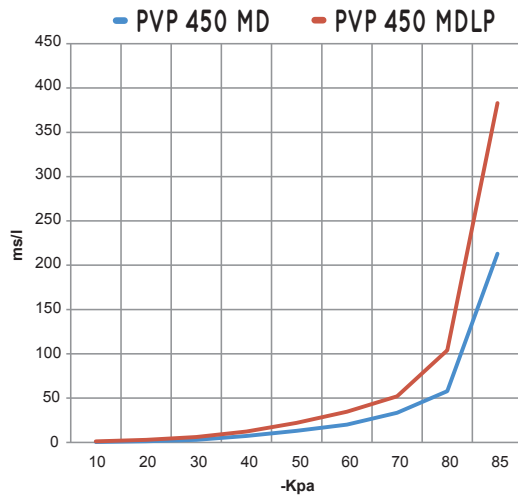

Generator item	Supp. press. bar	Air consumption NI/s	Evacuation rates (ms/l = s/m³) at different levels of vacuums (-KPa) at optimal supply pressure										Max vacuum -KPa
			10	20	30	40	50	60	70	80	85		
PVP 450 MD	6.0	47.8	0.5	1.4	3.0	7.4	13.2	20.1	33.5	57.9	213	90	
PVP 600 MD	6.0	63.2	0.4	1.0	2.4	5.7	10.2	15.6	25.9	44.8	165	90	
PVP 450 MDLP	3.0	65.8	1.2	3.0	6.2	12.4	22.0	34.7	52.0	104.1	383	88	
PVP 600 MDLP	3.0	87.7	0.8	2.0	4.1	8.2	14.6	23.1	34.7	69.4	256	88	