



MULTI-STAGE VACUUM GENERATORS PVP 40 ÷ 300 M / MLP

Created to be assembled on OCTOPUS gripping systems, this series of generators is available with suction capacities between 24 and 320 m³/h. The supply pressure goes from 4-6 bar for M items and from 1-3 bar for MLP items. Level of vacuum and flow rate can be adjusted according to the supply air pressure. Characterised by their new generation of ejectors, boasting an excellent ratio between the quantity of air consumed and that suctioned, benefiting operational consumption. The silencers are built into all generators. They are fully made with anodised aluminium, with stainless steel ejectors and screws. EPDM or VITON seals and reed valves upon request. Low maintenance and simple scheduled filter cleaning.



3D drawings are available on vuototecnica.net

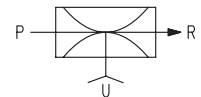
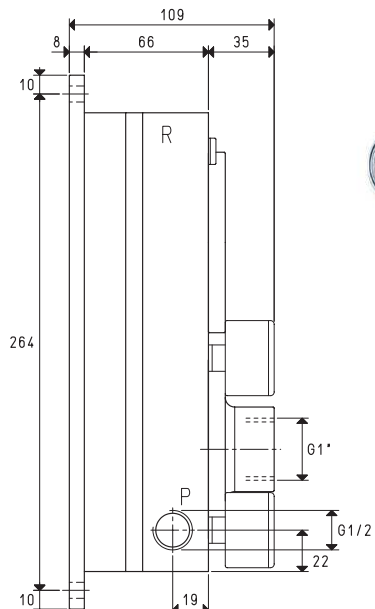
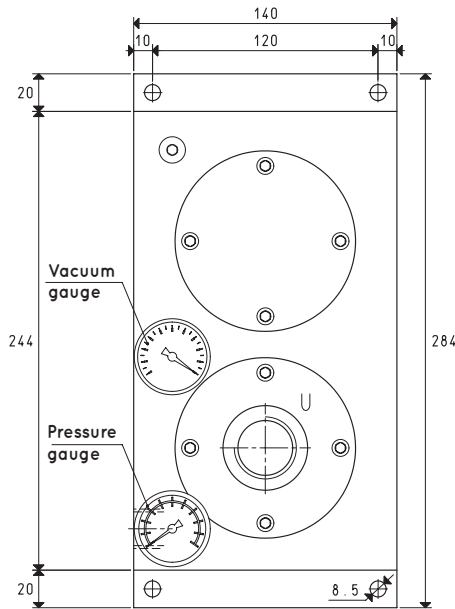

P=COMPRESSED AIR CONNECTION R=EXHAUST U=VACUUM CONNECTION

Item		PVP 40 M			PVP 70 M			PVP 100 M			
Intake air flow rate	m ³ /h	36	39	42	65	73	80	88	98	108	
Maximum level of vacuum	-KPa	65	82	90	65	82	90	65	82	90	
Final pressure	abs. mbar	350	180	100	350	180	100	350	180	100	
Supply pressure	bar	4	5	6	4	5	6	4	5	6	
Optimal supply pressure	bar			6			6			6	
Air consumption	NI/s	2.3	2.7	3.2	4.9	5.7	6.6	7.2	8.5	9.8	
Temperature of use	°C		-20 / +100				-20 / +100			-20 / +100	
Noise level at optimal supply pressure	dB(A)			67			68			70	
Weight	Kg			4.2			4.2			4.2	
Item		PVP 40 MLP			PVP 70 MLP			PVP 100 MLP			
Intake air flow rate	m ³ /h	24	35	41	41	56	73	50	80	95	
Maximum level of vacuum	-KPa	30	64	88	30	64	88	30	64	88	
Final pressure	abs. mbar	700	360	120	700	360	120	700	360	120	
Supply pressure	bar	1	2	3	1	2	3	1	2	3	
Optimal supply pressure	bar			3			3			3	
Air consumption	NI/s	2.4	3.4	4.4	4.6	7.0	8.9	6.7	10.2	13.3	
Temperature of use	°C		-20 / +100				-20 / +100			-20 / +100	
Noise level at optimal supply pressure	dB(A)			70			72			75	
Weight	Kg			4.2			4.2			4.2	
Spare parts		PVP 40 M / MLP			PVP 70 M / MLP			PVP 100 M / MLP			
Sealing kit and reed valves	item	00 KIT PVP 40 M			00 KIT PVP 70 M			00 KIT PVP 100 M			
Exhaust silencer	item	00 15 110			00 15 110			00 15 110			
Silencer on nozzles	item	00 15 111			00 15 111			00 15 111			
Vacuum gauge	item	09 03 15			09 03 15			09 03 15			
Pressure gauge	item	09 03 25			09 03 25			09 03 25			

Note: All vacuum values indicated in the table are valid at the normal atmospheric pressure of 1013 mbar and obtained with a constant supply pressure.

Vacuum generator supply must be carried out with non-lubricated compressed air, 5 micron filtration, in accordance with standard ISO 8573-1 class 4.

Transformation ratio: N (newton) = Kg x 9.81 (force of gravity)

inch = $\frac{mm}{25.4}$; pounds = $\frac{g}{453.6} = \frac{Kg}{0.4536}$

Adapters for GAS - NPT threading available on page 1.130



MULTI-STAGE VACUUM GENERATORS PVP 40, PVP 70 and PVP 100 M / MLP

Air flow rate (NI/s) at different levels of vacuums (-KPa) at optimal supply pressure

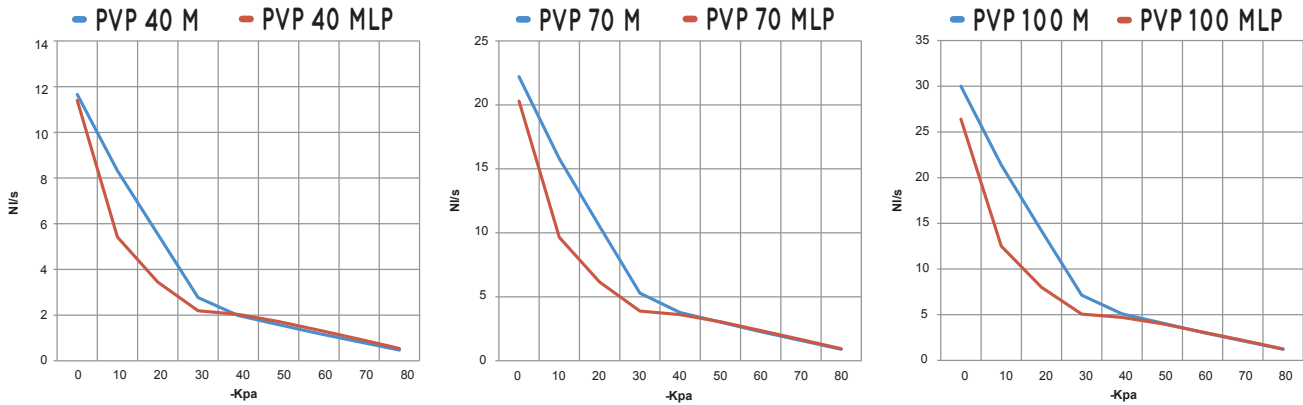

Generator item	Supp. press. bar	Air consumption NI/s	Air flow rate (NI/s) at different levels of vacuums (-KPa) at optimal supply pressure										Max vacuum -KPa
			0	10	20	30	40	50	60	70	80		
PVP 40 M	6.0	3.2	11.66	8.32	5.55	2.77	1.98	1.58	1.19	0.83	0.47	90	
PVP 70 M	6.0	6.6	22.20	15.80	10.50	5.29	3.77	3.02	2.27	1.58	0.90	90	
PVP 100 M	6.0	9.8	30.00	21.40	14.20	7.14	5.10	4.08	3.06	2.14	1.22	90	
PVP 40 MLP	3.0	4.4	11.40	5.42	3.45	2.19	2.03	1.72	1.34	0.95	0.54	88	
PVP 70 MLP	3.0	8.9	20.30	9.65	6.15	3.88	3.61	3.05	2.36	1.66	0.94	88	
PVP 100 MLP	3.0	13.3	26.40	12.50	8.00	5.07	4.70	4.00	3.10	2.20	1.25	88	

Evacuation rates (ms/l = s/m³) at different levels of vacuums (-KPa) at optimal supply pressure

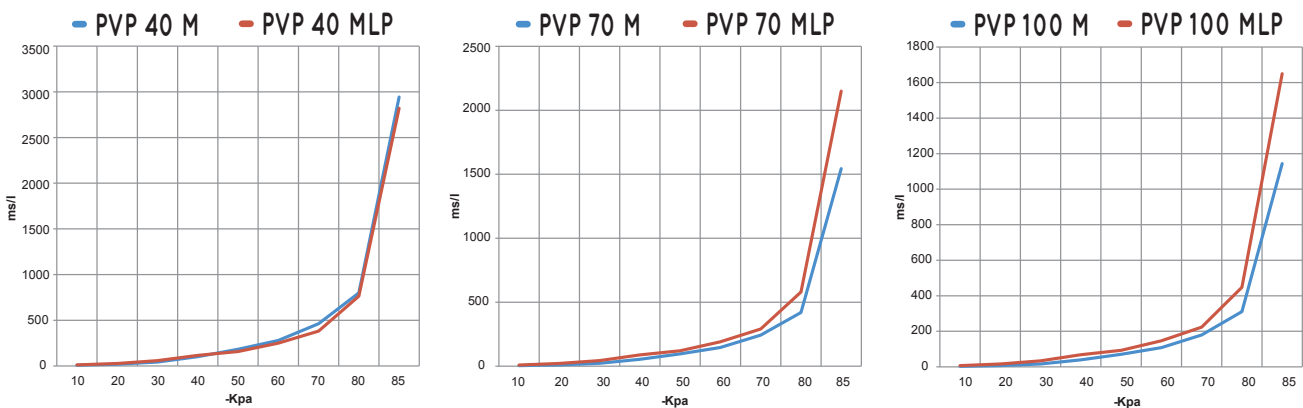

Generator item	Supp. press. bar	Air consumption NI/s	Evacuation rates (ms/l = s/m ³) at different levels of vacuums (-KPa) at optimal supply pressure										Max vacuum -KPa
			10	20	30	40	50	60	70	80	85		
PVP 40 M	6.0	3.2	7.7	19.2	42.3	101.6	182.0	278.4	462.3	799.8	2943	90	
PVP 70 M	6.0	6.6	4.0	10.1	22.2	53.3	95.5	146.1	242.6	419.7	1544	90	
PVP 100 M	6.0	9.8	3.0	7.4	16.4	39.5	70.7	108.2	179.6	310.8	1144	90	
PVP 40 MLP	3.0	4.4	12.0	28.0	58.0	116.0	158.0	250.0	382.0	764.0	2820	88	
PVP 70 MLP	3.0	8.9	9.0	21.0	44.0	88.0	120.0	190.0	290.0	580.0	2150	88	
PVP 100 MLP	3.0	13.3	7.0	16.0	34.0	68.0	93.0	147.0	224.0	448.0	1650	88	