

# IN-LINE SINGLE-STAGE VACUUM GENERATOR PVP 1

This new range of vacuum generators also makes use of the Venturi principle. Their distinctive feature compared with traditional vacuum generators are the two air and vacuum supply connections located in-line on the same axis, while the exhaust connection of the sucked and exhaust air is orthogonal to them and is located on the generator circumference. These vacuum generators are easy to disassemble, thus allowing visibility and access to all the components. The advantages of these generators include reduced overall dimensions, easy maintenance and easy assembly to the vacuum cup supports or to the vacuum cup holders. As a standard, they are equipped with pressed stainless steel suction filter and a special microfibre silencer, which is wrapped around the exhaust connection, making them particularly silent. They are fully made with anodised aluminium.

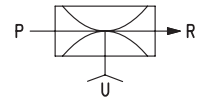
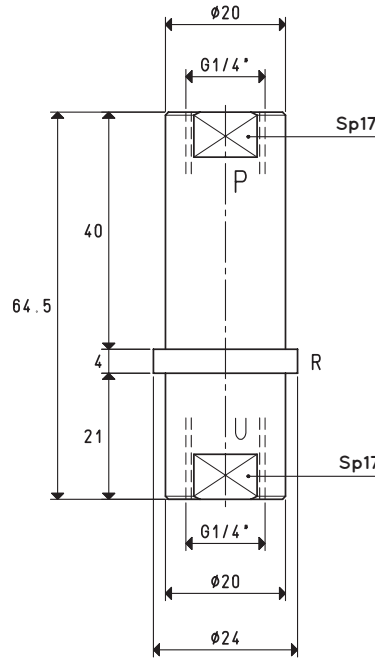

P=COMPRESSED AIR CONNECTION      R=EXHAUST      U=VACUUM CONNECTION

Item		PVP 1		
Intake air flow rate	m <sup>3</sup> /h	0.9	1.0	1.0
Maximum level of vacuum	-KPa	60	80	85
Final pressure	mbar abs.	400	200	150
Supply pressure	bar	3	4	5
Optimal supply pressure	bar			5
Air consumption	NI/s	0.30	0.35	0.45
Operating temperature	°C			-20 / +80
Noise level at optimal supply pressure	dB(A)			62
Weight	g			44
Spare parts		PVP 1		
Silencer	item		00 15 114	
Suction filter	item		SP 1/4 I	

Note: All vacuum values indicated in the table are valid at the normal atmospheric pressure of 1013 mbar and obtained with a constant supply pressure.

Vacuum generator supply must be carried out with non-lubricated compressed air, 5 micron filtration, in accordance with standard ISO 8573-1 class 4.



# IN-LINE SINGLE-STAGE VACUUM GENERATOR PVP 1

3D drawings are available on vuototecnica.net

Air flow rate (NI/s) at different level of vacuum (-KPa) at optimal supply pressure

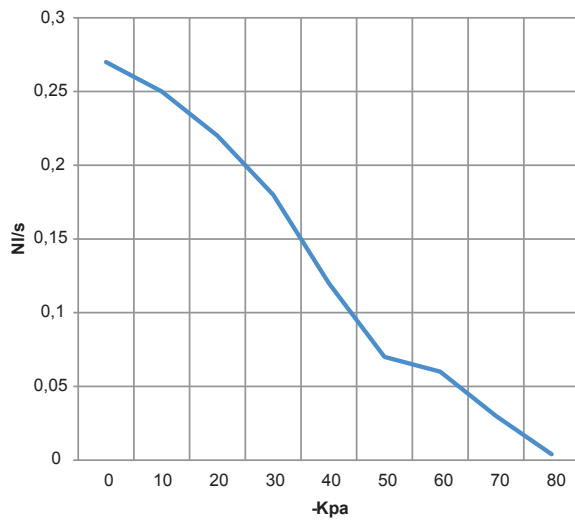

Generator item	Supp. press. bar	Air consumption NI/s	Air flow rate (NI/s) at different levels of vacuums (-KPa) at optimal supply pressure										Max vacuum -KPa
			0	10	20	30	40	50	60	70	80		
PVP 1	5.0	0.45	0.27	0.25	0.22	0.18	0.12	0.07	0.06	0.03	--	85	

Evacuation rates (ms/l = s/m<sup>3</sup>) at different levels of vacuums (-KPa) at optimal supply pressure

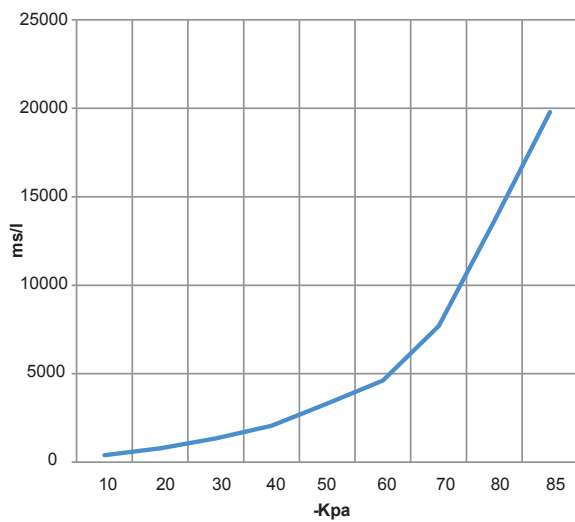

Generator item	Supp. press. bar	Air consumption NI/s	Evacuation rates (ms/l = s/m <sup>3</sup> ) at different levels of vacuums (-KPa) at optimal supply pressure									Max vacuum -KPa
			10	20	30	40	50	60	70	80	85	
PVP 1	5.0	0.45	393	786	1336	2057	3312	4605	7690	13935	19787	85