

SINGLE-STAGE VACUUM GENERATORS PVP 05, PVP 2 and PVP 3



3D drawings are available on vuototecnica.net

With their extremely reduced size and high performance, these single-stage vacuum generators operate making use of the Venturi principle. Supplying the generator with compressed air in P, vacuum will be generated at connection U, while both the supply and the sucked air will be released through R. By interrupting the air supply in P, the vacuum effect in U will also stop.

The vacuum generators described on this page are generally used for interconnecting vacuum cups, for gripping and handling non-porous objects and equipment with low flow rate requirements.

They are made with anodised aluminium, with ejectors in aluminium (PVP05) or in brass (PVP2 - PVP3).

Upon request, they can be supplied with a high sound suppression silencer installed on the R exhaust connection.

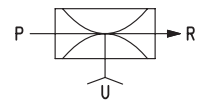
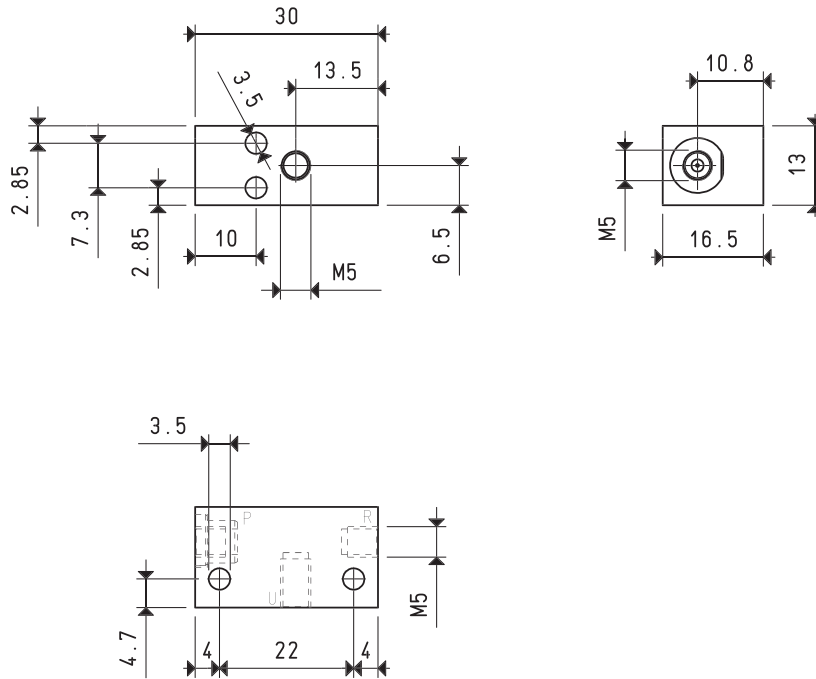

Item	P=COMPRESSED AIR CONNECTION	R=EXHAUST	U=VACUUM CONNECTION				
			PVP 05				
Intake air flow rate	m ³ /h	0.36	0.42	0.42	0.47	0.50	0.50
Maximum level of vacuum	-KPa	22	33	42	48	61	82
Final pressure	mbar abs.	780	670	580	520	390	180
Supply pressure	bar	1	2	3	4	5	6
Optimal supply pressure	bar						6
Air consumption	NI/s	0.13	0.20	0.27	0.34	0.40	0.50
Operating temperature	°C						-20 / +80
Noise level at optimal supply pressure	dB(A)						70
Weight	g						14

Note: All vacuum values indicated in the table are valid at the normal atmospheric pressure of 1013 mbar and obtained with a constant supply pressure.

Vacuum generator supply must be carried out with non-lubricated compressed air, 5 micron filtration, in accordance with standard ISO 8573-1 class 4.

Transformation ratio: N (newton) = Kg x 9.81 (force of gravity)

inch = $\frac{\text{mm}}{25.4}$; pounds = $\frac{\text{g}}{453.6} = \frac{\text{Kg}}{0.4536}$

Adapters for GAS - NPT threading available on page 1.130



SINGLE-STAGE VACUUM GENERATOR PVP 05

Air flow rate (NI/s) at different level of vacuum (-KPa) at optimal supply pressure

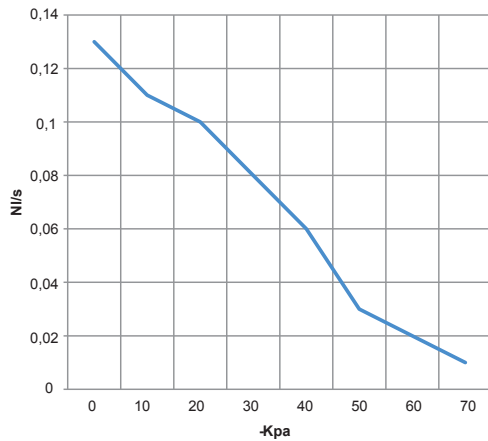

Generator item	Supp. press. bar	Air consumption NI/s	Air flow rate (NI/s) at different levels of vacuums (-KPa) at optimal supply pressure										Max vacuum -KPa
			0	10	20	30	40	50	60	70	80		
PVP 05	6.0	0.5	0.13	0.11	0.10	0.08	0.06	0.03	0.02	0.01	--	82	

Evacuation rates (ms/l = s/m³) at different levels of vacuums (-KPa) at optimal supply pressure

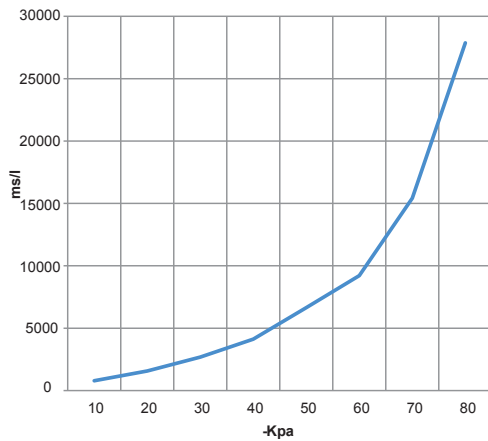

Generator item	Supp. press. bar	Air consumption NI/s	Evacuation rates (ms/l = s/m ³) at different levels of vacuums (-KPa) at optimal supply pressure								Max vacuum -KPa
			10	20	30	40	50	60	70	80	
PVP 05	6.0	0.5	786	1572	2678	4126	6644	9210	15420	27870	82

ACCESSORIES UPON REQUEST

Silencer item FB 1

