

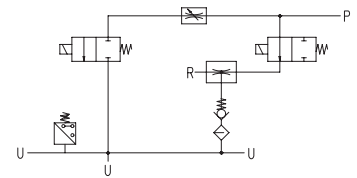

MULTI-STAGE, MULTI-FUNCTION AND MODULAR VACUUM GENERATORS, GVMM 10 and GVMM 14

3D drawings are available on vuototecnica.net

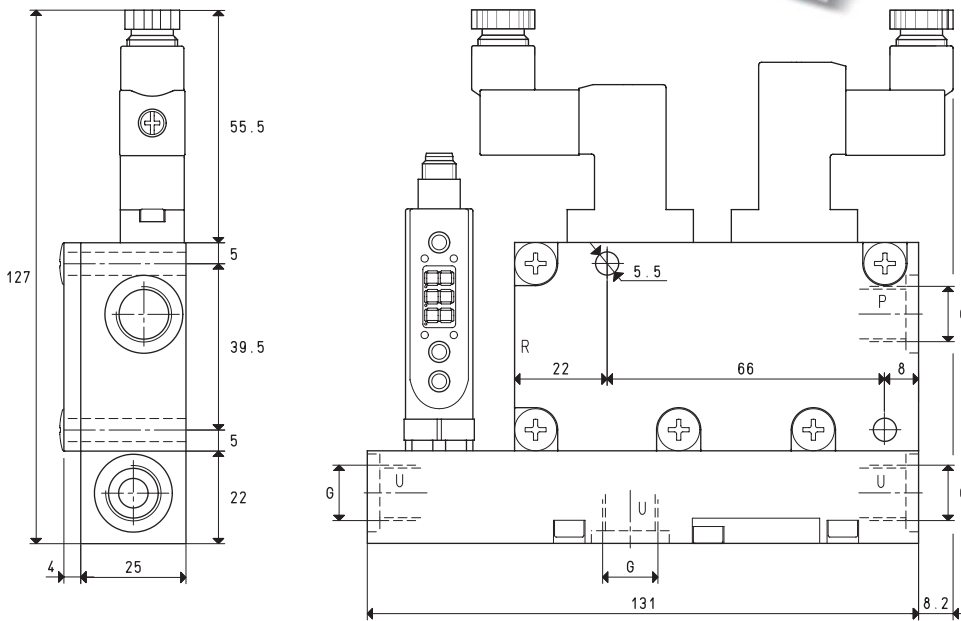

P=COMPRESSED AIR CONNECTION R=EXHAUST U=VACUUM CONNECTION

Item		GVMM 10			GVMM 14		
Intake air flow rate	m ³ /h	7.5	8.3	9.1	10.1	11.1	12.1
Maximum level of vacuum	-KPa	60	80	85	60	80	85
Final pressure	mbar abs.	400	200	150	400	200	150
Supply pressure	bar	3	4	5	3	4	5
Optimal supply pressure	bar			5			5
Air consumption	NI/s	1.1	1.4	1.7	1.4	1.7	2.1
Max quantity of air blown at 5 bar	l/min			128			128
Supply solenoid valve position	NO/NC			NO			NO
Electrical absorption	W			2			2
Ejection solenoid valve position	NC			NC			NC
Electrical absorption	W			4			4
Supply voltage	V			24DC			24DC
Vacuum switch output				PNP			PNP
Degree of protection	IP			65			65
Temperature of use	°C			-10 / +60			-10 / +60
Noise level at optimal supply pressure	dB(A)			70			72
Weight	g			460			460
G	Ø			G1/4"			G1/4"

Note: To order a generator without a digital vacuum switch, indicate code GVMM .. SV.

To order a generator with NC supply solenoid valve, indicate code GVMM .. NC.

Note: All vacuum values indicated in the table are valid at the normal atmospheric pressure of 1013 mbar and obtained with a constant supply pressure.

Vacuum generator supply must be carried out with non-lubricated compressed air, 5 micron filtration, in accordance with standard ISO 8573-1 class 4.

Transformation ratio: N (newton) = Kg x 9.81 (force of gravity)

inch = $\frac{\text{mm}}{25.4}$; pounds = $\frac{\text{g}}{453.6} = \frac{\text{Kg}}{0.4536}$

Adapters for GAS - NPT threading available on page 1.130



Air flow rate (NI/s) at different level of vacuum (-KPa) at optimal supply pressure

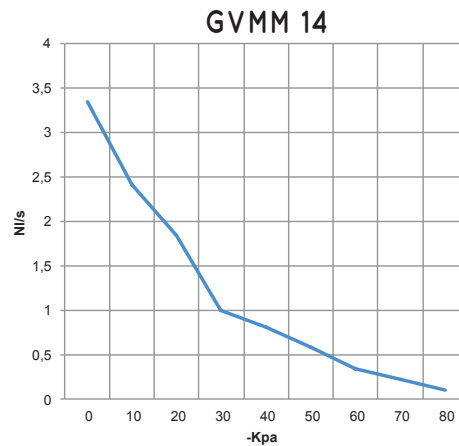
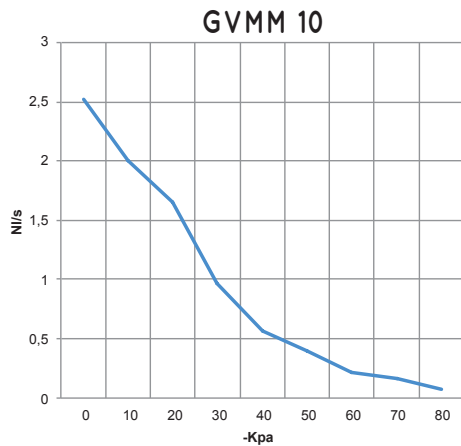

Generator item	Supp. press. bar	Air consumption NI/s	Air flow rate (NI/s) at different levels of vacuums (-KPa) at optimal supply pressure										Max vacuum -KPa
			0	10	20	30	40	50	60	70	80		
GVMM 10	5.0	1.7	2.52	2.00	1.66	0.97	0.56	0.40	0.22	0.16	0.07	85	
GVMM 14	5.0	2.1	3.35	2.42	1.84	0.99	0.80	0.58	0.34	0.22	0.10	85	

Evacuation rates (ms/l = s/m³) at different levels of vacuums (-KPa) at optimal supply pressure

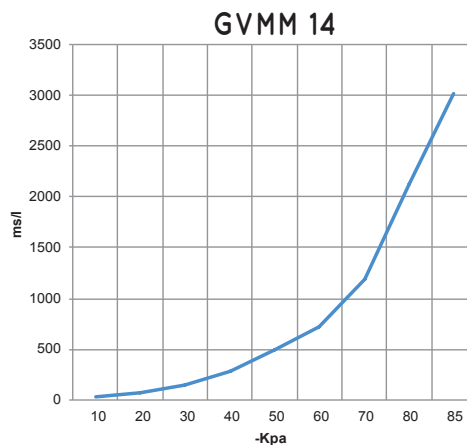
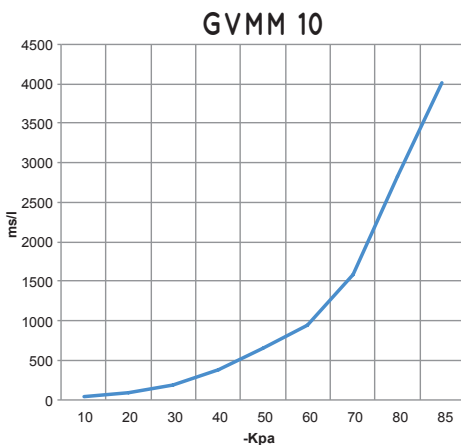

Generator item	Supp. press. bar	Air consumption NI/s	Evacuation rates (ms/l= s/m ³) at different levels of vacuums (-KPa) at optimal supply pressure										Max vacuum -KPa
			10	20	30	40	50	60	70	80	85		
GVMM 10	5.0	1.7	42	97	195	384	651	951	1589	2828	4016	85	
GVMM 14	5.0	2.1	31	72	146	288	489	714	1193	2124	3016	85	

ACCESSORIES AND SPARE PARTS UPON REQUEST

Item		GVMM 10	GVMM 14
Sealing kit and reed valves	item	00 KIT GVMM 10	00 KIT GVMM 14
Exhaust silencer	item		N°2 00 15 150
Electrical connection cable with axial connector, for vacuum switch	item		00 12 20
Electrical connection cable with radial connector, for vacuum switch	item		00 12 21
Set of electrical connection cables, with built-in NO energy saving device and connectors	item		00 15 202
Set of electrical connection cables, with built-in NC energy saving device and connectors	item		00 15 203
Digital vacuum switch	item		12 10 10
NO supply solenoid valve	item		00 15 176
NC supply solenoid valve	item		00 15 175