

## PNEUMATIC DEVICES FOR THE POWER SUPPLY OF MINI PNEUMATIC PUMP SETS DOP 06, DOP 10, DOP 20 AND PUMP SETS DOP 25, DOP 50, DOP 100, DOP 150 and DOP 300

The pneumatic equipment of the mini pump sets and pump sets is sized so as to guarantee the right amount of compressed air supply to the vacuum generators installed on them, at a correct, constant and continuous pressure.

It is composed of:

- A pressure regulator with filter and pressure gauge for regulating compressed supply air
- A metal bracket for fixing the pressure regulator to the support
- A slide valve to intercept compressed air
- Two quick couplings to connect the air supply line and the vacuum generator

They are available in different sizes depending on the vacuum generator installed on the mini pump set or on the pump set.

## PNEUMATIC DEVICES FOR THE POWER SUPPLY OF MINI PNEUMATIC PUMP SETS DOP 06, DOP 10 and DOP 20

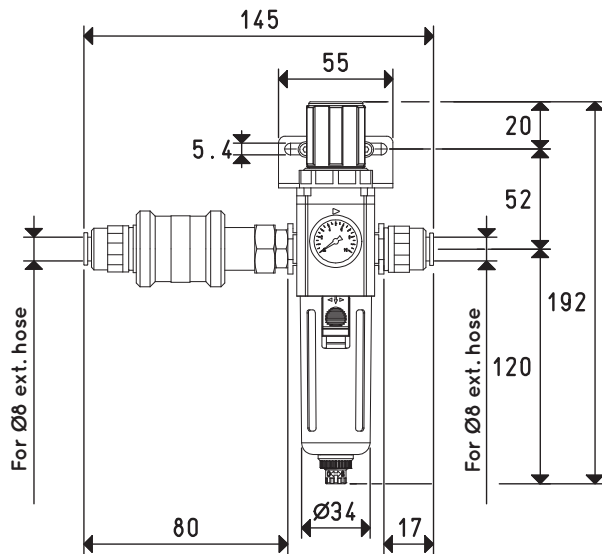

Item	Weight Kg	Suitable for generator item
DOP 20 90	0.36	PVP 12 MX - PVP 25 MX - PVP 25 MDX ES - PVP 35 MDX ES - PVP 50 MDX ES