

1 - COAXIAL SHUTTER SERVO-CONTROLLED SUPPLY VALVE

This is an innovative valve with coaxial shutter, pneumatically driven by the integrated vacuum switch on it, able to intercept the compressed air supply to the vacuum generator, with operating pressures between 1.5 and 7 bar. The vacuum switch has the task of removing and returning a pneumatic signal when a preset and adjustable level of vacuum is reached. The pressure differential existing between the set maximum value and that of restoring the signal at rest is not adjustable and is equal to about 100 mbar. The pneumatic vacuum switch, acting on the coaxial shutter supply valve automatically maintains the maximum and minimum level of vacuum within the differential value.

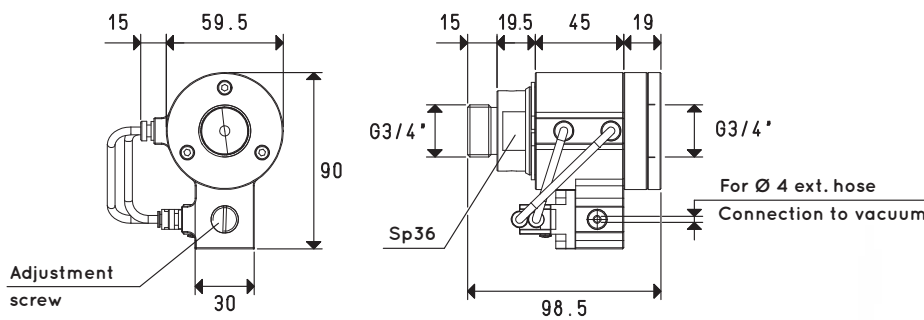

Item	For generator item	Weight g
07 04 71	PVP 150 ÷ 750 MD/MDLP	570