

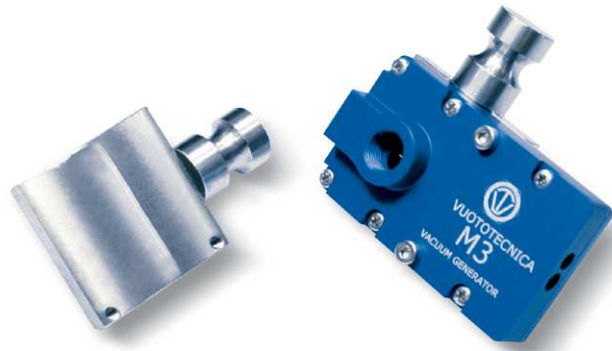

FIXING SUPPORTS FOR MULTI-STAGE VACUUM GENERATORS, SERIES M

The supports illustrated and described on this page are made in anodised aluminium as a standard but, upon request, they can be supplied in the stainless steel version. These supports are for fixing the multi-stage vacuum generators of the series M to the machine via a cylindrical slotted pin or a ball pin housed in the machine itself. They are suited for robotic gripping systems and they allow for easy vacuum generator installation on the profiles used in the automotive sector.

3D drawings are available on vuototecnica.net

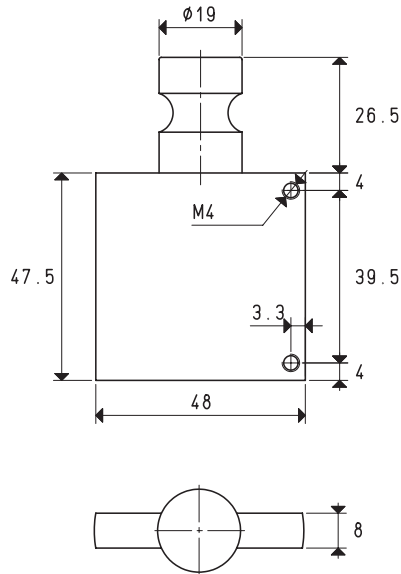

Item	By generators	Material	Weight g
00 FCH 23	M 3 - M 7 - M 10 - M 14 - M 18	aluminium	63
00 FCH 22	M 3 - M 7 - M 10 - M 14 - M 18	stainless steel	191

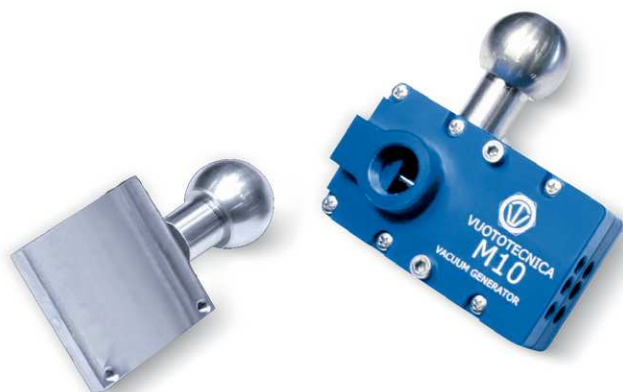
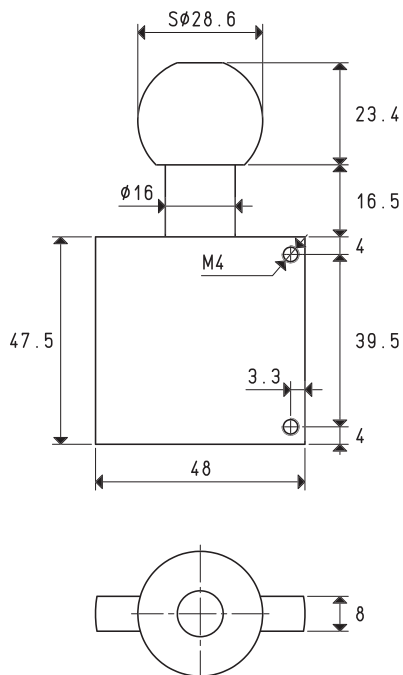

Item	By generators	Material	Weight g
00 FCH 13	M 3 - M 7 - M 10 - M 14 - M 18	aluminium	85
00 FCH 12	M 3 - M 7 - M 10 - M 14 - M 18	stainless steel	256

Transformation ratio: N (newton) = Kg x 9.81 (force of gravity)

$$\text{inch} = \frac{\text{mm}}{25.4} ; \text{pounds} = \frac{\text{g}}{453.6} = \frac{\text{Kg}}{0.4536}$$