

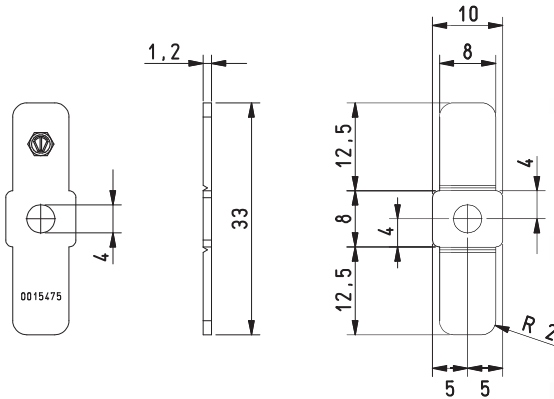

② - REED VALVE KIT FOR CHECK DEVICE ON VACUUM GENERATORS

This reed valve kit, specifically designed to be integrated on PVP 150/750 MD/MDLP vacuum generators, has the task of preventing the return of atmospheric air into the vacuum system (tanks, autoclaves, intake systems depression, vacuum cups, etc.), when the generator stops, guaranteeing the seal and maintaining the level of vacuum reached in use.



Item	For generator item	No. pc.	Weight g
00 KIT TRASMD-MDR	PVP 150 ÷ 750 MD/MDLP	6	16

③ - FLEXIBLE TUBE FOR CONNECTION TO VACUUM

This flexible tube is fitted on one end with a 1/8" quick-fit coupling, to be screwed onto one of the two vacuum generator connections reserved for the vacuum gauge, while the other free end is inserted into the fitting installed on the pneumatic vacuum switch. The task of this tube is to continuously monitor the value of the level of vacuum reached in use and to transmit it to the vacuum switch.

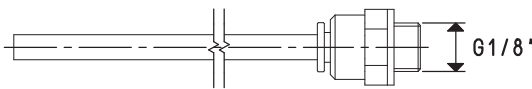

Item	For supply valve item	Weight g
00 15 496	07 03 71 - 07 04 71	10

COMPLETE KIT FOR ENERGY SAVING DEVICE ES

The three components described above make up an energy saving kit for the compressed air supply ES (Energy Saving System). In fact, the ES device acts directly on the generator, making it operate only within the preset vacuum values, thus limiting compressed air supply consumption; all this entails considerable energy savings.

This kit has been specifically designed for the PVP 150-750 MD/MDLP series of generators.



Item	For generator item	Weight g
ES 05	PVP 150 ÷ 750 MD/MDLP	596