

# REGULATORS FOR ROUGH VACUUM LEVELS

The regulators on this page are based on the same operation principle as the ones described in the previous page and have the same function. The only difference is that in these ones the minimum adjustable level of vacuum is close to the atmospheric pressure value. The level of vacuum is adjusted manually by turning the knurled thumb screw clockwise to increase it, and counter clockwise to decrease it.

### Technical features

- Operation: membrane-piston regulator
- Adjustable operating pressure: from 980 to 1 mbar abs.
- Flow rate: from 20 to 160 m<sup>3</sup>/h
- Room temperature: from -10 to +80 °C
- Installation position: any

### Usage

These regulators are used as the previously described ones, but they offer the additional advantage of regulating even levels of vacuum close to the atmospheric pressure.



3D drawings are available on [vuotecnica.net](http://vuotecnica.net)

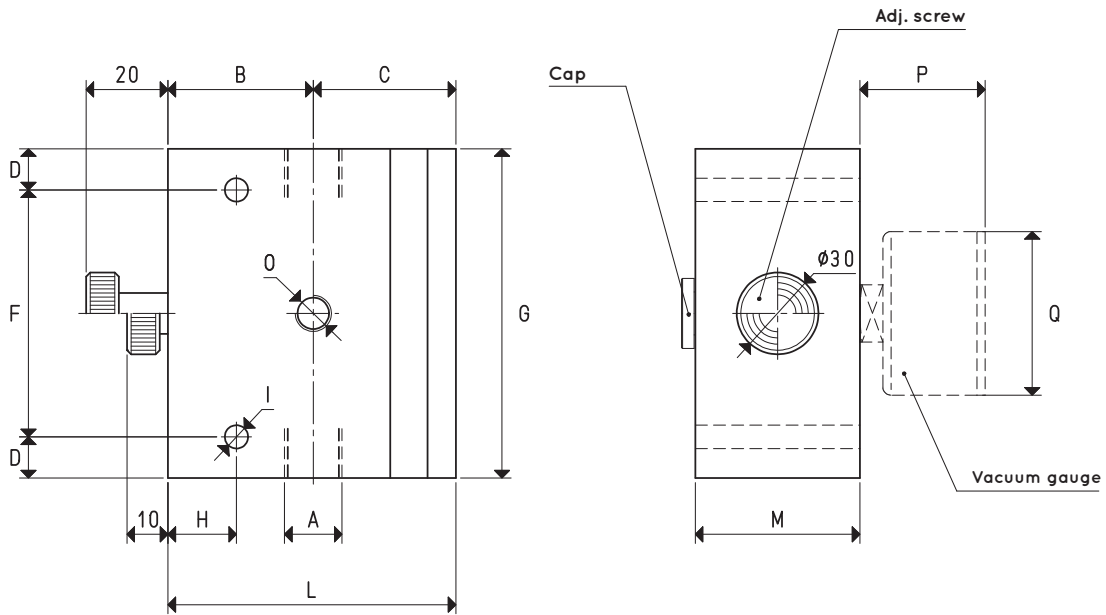

Item	A Ø	Max capac. m <sup>3</sup> /h	B	C	D	F	G	H	I Ø	L	M	O Ø	P	Q Ø	Vacuum gauge item	Weight Kg
<b>11 03 50</b>	G1/2"	20	53	52.0	15	90	120	25	8.5	105.0	60	G1/4"	36	63	09 03 10	2.07
<b>11 05 50</b>	G1"	80	60	58.0	15	90	120	30	8.5	118.0	100	G1/4"	36	63	09 03 10	3.74
<b>11 06 50</b>	G1" 1/2	160	54	77.5	15	130	160	20	8.5	131.5	99	G1/4"	36	63	09 03 10	5.54

Note: The vacuum gauges are not integral parts of the regulators and, therefore, must be ordered separately

Transformation ratio: N (newton) = Kg x 9.81 (force of gravity)

inch =  $\frac{\text{mm}}{25.4}$ ; pounds =  $\frac{\text{g}}{453.6} = \frac{\text{Kg}}{0.4536}$

Adapters for GAS - NPT threading available on page 1.130