

## VACUUM GAUGE WITH STEEL PUNCH

This vacuum gauge with punch has been designed to allow the immediate detection of the level of vacuum inside tin cans and food containers in general.

The glycerine bath vacuum gauge item 09 05 16 used for this application (features described on the previous page) is provided with a hardened steel punch to easily perforate the containers and with a vacuum cup in silicon compound to guarantee vacuum seal after perforation.

It is available in the standard version, which is the one shown on this page, but can be provided in other versions upon request.

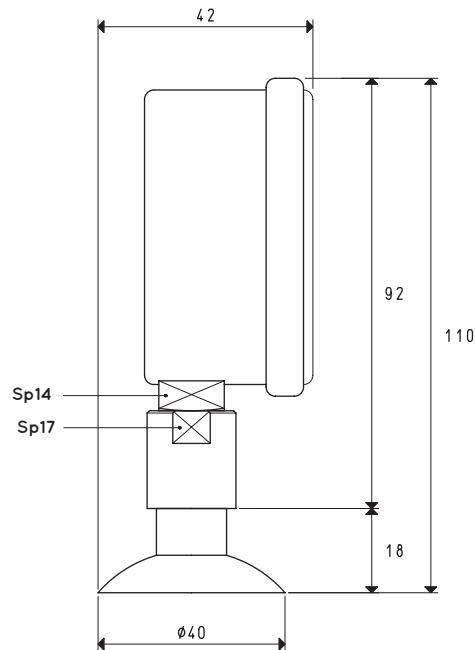
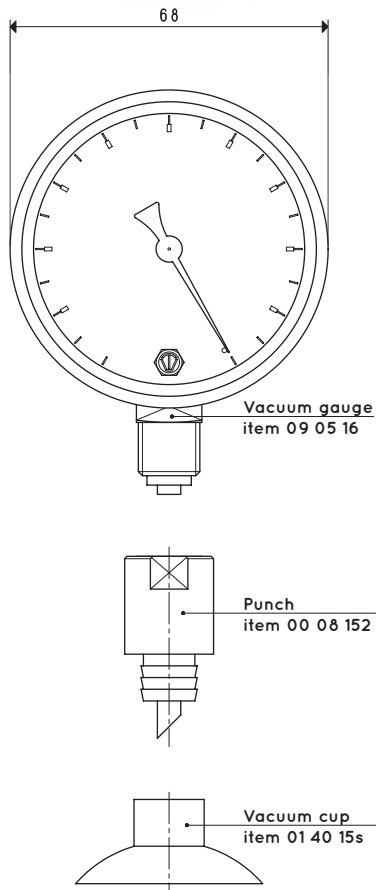
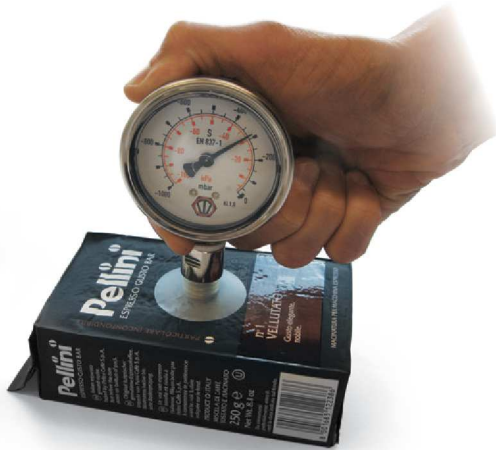

### VACUUM GAUGE

Item	Scale mbar	Double Scale KPa	Admissible scale error	Temperature of use	Notes	Case material	Weight g
09 05 99	0 ÷ -1000	0 ÷ -100	1.6%	-10 °C ÷ +50 °C	in glycerine bath	stainless steel	250