



FCL IN-LINE SUCTION FILTERS, WITH PAPER CARTRIDGE

These small in-line filters retain impurities and very fine dust, interfering with the flow rate in a negligible manner. Thanks to their reduced size, they can be directly installed onto vacuum piping, close to the utilities (vacuum cups, vacuum clamping systems, etc.) for a fractionated filtration and a better visual control of all the plant suction points.

They are composed of a cylindrical transparent Plexiglass body closed by two anodised aluminium flanges kept in place by Seeger rings, where all the threaded male or female connections and seals are located. Inside there is a filtering cartridge with a filtering degree equal to $7\ \mu$, which is made with a special treated paper that is pleated to increase the filtering surface. The filters can be inspected by simply removing one of the two flanges. Due to the paper filtering element, these filters are not recommended in presence of water or oil vapours or condensations.

Technical features

Operating pressure: from 0.5 to 3000 absolute mbar

Fluid temperature: from -20 to $+60^{\circ}\text{C}$

Level of filtration: $7\ \mu$

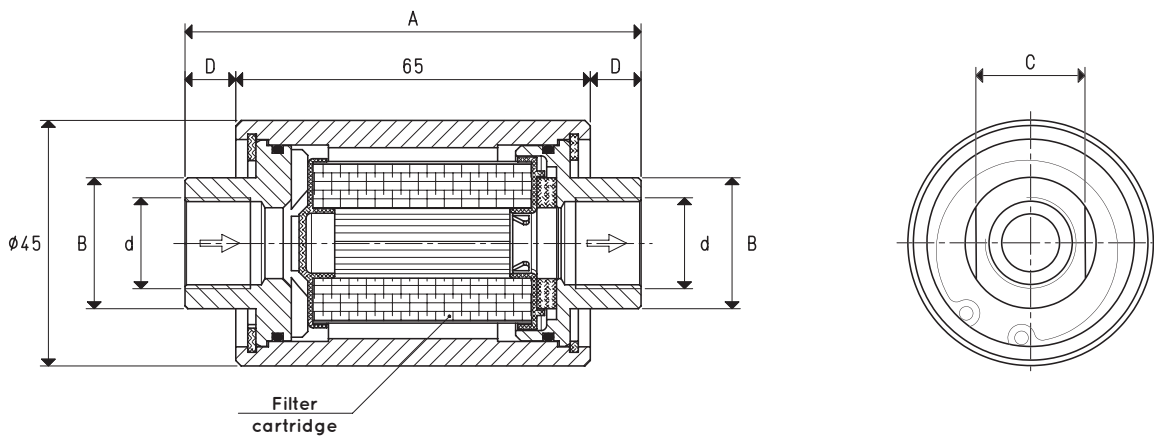

Item	d \emptyset	A	B \emptyset	C	D	Flow rate max m^3/h	Cartridge spare part item	Sealing kit spare part item	Weight g
FCL 1	G1/4"	79.2	20.0	17	7.1	7.5	00 FCL 03	00 KIT FCL 1	120
FCL 2	G3/8"	83.6	24.0	20	9.3	20.0	00 FCL 03	00 KIT FCL 1	136
FCL 3	G1/2"	89.6	26.5	24	12.3	25.0	00 FCL 03	00 KIT FCL 1	152

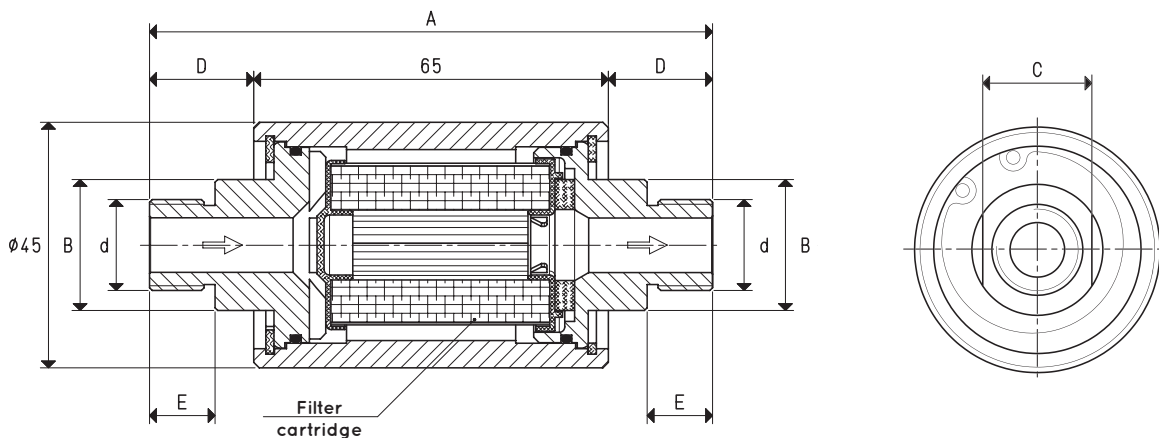

Item	d \emptyset	A	B \emptyset	C	D	E	Flow rate max m^3/h	Cartridge spare part item	Sealing kit spare part item	Weight g
FCL 1 M	G1/4"	103.2	20.0	17	19.1	12	7.5	00 FCL 03	00 KIT FCL 1	122
FCL 2 M	G3/8"	103.2	24.0	20	19.1	12	20.0	00 FCL 03	00 KIT FCL 1	138
FCL 3 M	G1/2"	113.6	26.5	24	24.3	15	25.0	00 FCL 03	00 KIT FCL 1	154

Transformation ratio: N (newton) = Kg x 9.81 (force of gravity)

inch = $\frac{\text{mm}}{25.4}$; pounds = $\frac{\text{g}}{453.6} = \frac{\text{Kg}}{0.4536}$

Adapters for GAS - NPT threading available on page 1.130



FCL IN-LINE SUCTION FILTERS, WITH PAPER CARTRIDGE

3D drawings are available on vuotecnica.net

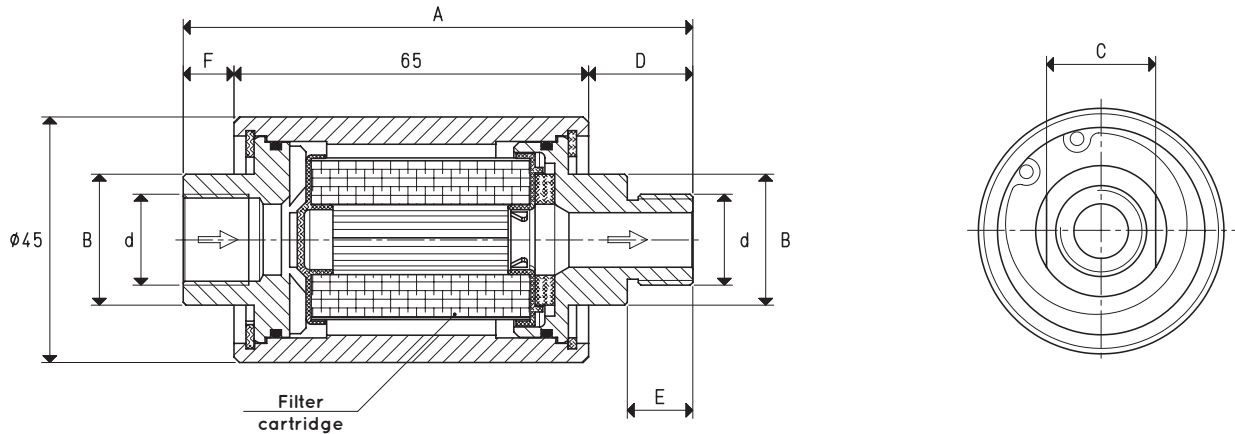

Item	d Ø	A	B Ø	C	D	E	F	Flow rate max m ³ /h	Cartridge spare part item	Sealing kit spare part item	Weight g
FCL 1 MF	G1/4"	91.2	20.0	17	19.1	12	7.1	7.5	00 FCL 03	00 KIT FCL 1	120
FCL 2 MF	G3/8"	93.4	24.0	20	19.1	12	9.3	20	00 FCL 03	00 KIT FCL 1	136
FCL 3 MF	G1/2"	101.6	26.5	24	24.3	15	12.3	25	00 FCL 03	00 KIT FCL 1	152

PAPER FILTERING CARTRIDGES FOR FCL FILTERS

The cartridges described below are suited for FCL filters. They are made with a special treated paper with a filtering degree equal to 7 µ, which is pleated in order to increase its surface and wrapped on two flanges in plastic material. They are recommended for retaining impurities and fine dust, but not in presence of water or oil vapours or condensations.

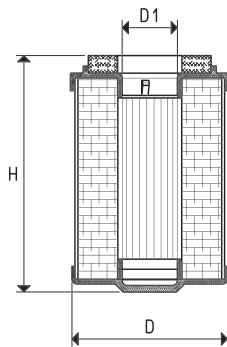

Item	For filter item	D Ø	D1 Ø	H	Level of filtration micron
00 FCL 03	FCL 1 - FCL 2 - FCL 3 FCL 1 M - FCL 2 M - FCL 3 M FCL 1 MF - FCL 2 MF - FCL 3 MF	31	10	47	5 ÷ 7

Transformation ratio: N (newton) = Kg x 9.81 (force of gravity)

inch = $\frac{\text{mm}}{25.4}$; pounds = $\frac{\text{g}}{453.6} = \frac{\text{Kg}}{0.4536}$

Adapters for GAS - NPT threading available on page 1.130