

FB SUCTION FILTER WITH METAL CARTRIDGE

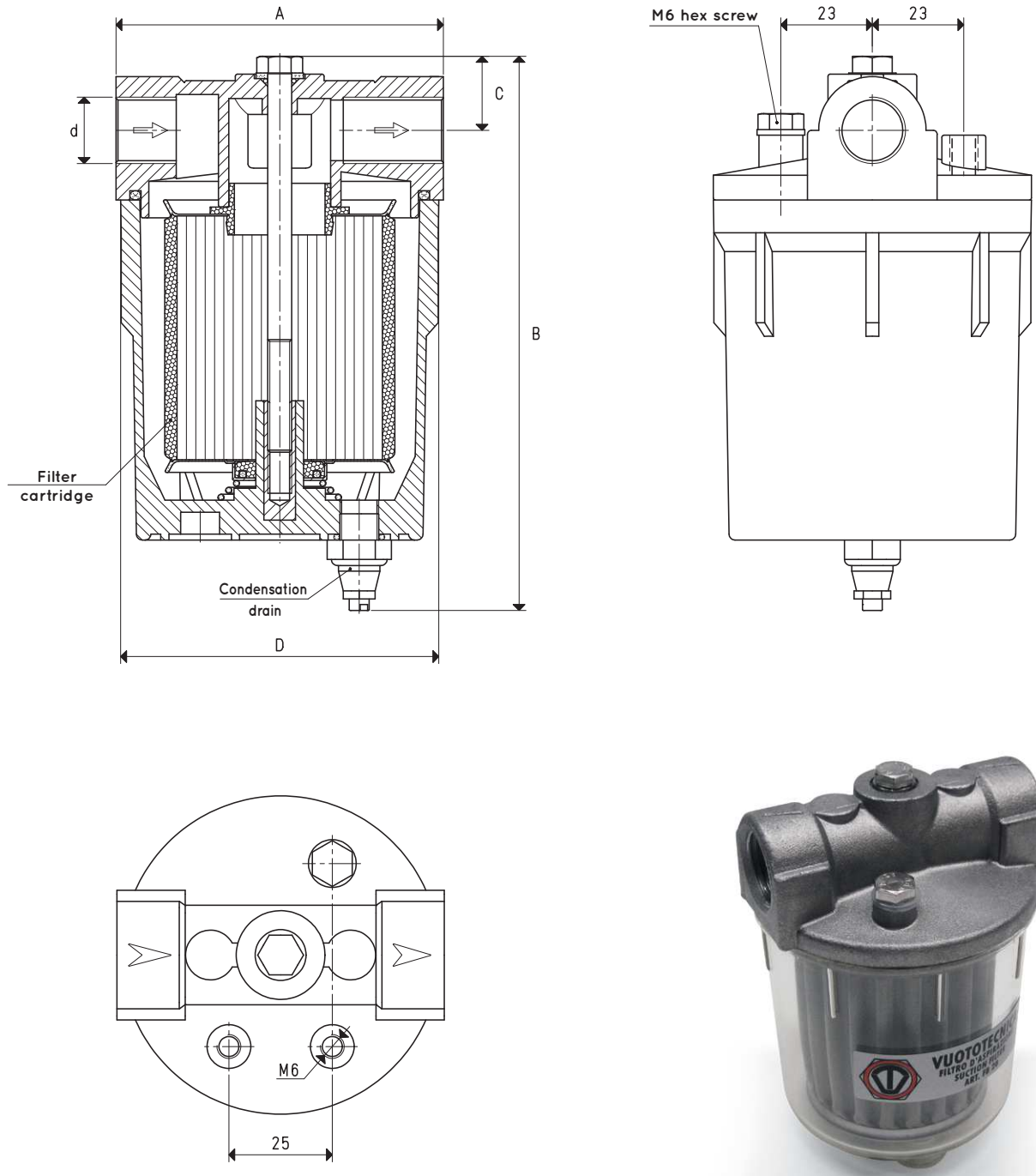

3D drawings are available on vuototecnica.net



5

Item	d Ø	A	B	C	D Ø	Flow rate max m ³ /h	Cartridge spare part item	Sealing kit and small parts item	Weight g
FB 20	G1/2"	81	116	17	79	20	00 FB 22	00 KIT FB20	312

Transformation ratio: N (newton) = Kg x 9.81 (force of gravity)

$$\text{inch} = \frac{\text{mm}}{25.4}; \text{pounds} = \frac{\text{g}}{453.6} = \frac{\text{Kg}}{0.4536}$$

Adapters for GAS - NPT threading available on page 1.130



FB SUCTION FILTER WITH METAL CARTRIDGE

3D drawings are available on vuototecnica.net

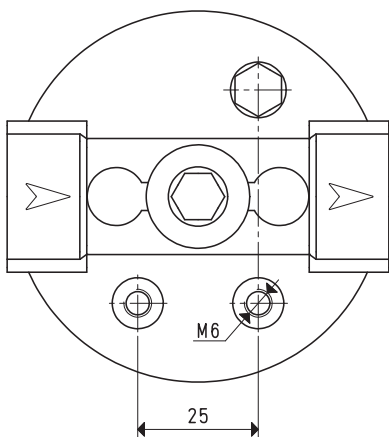
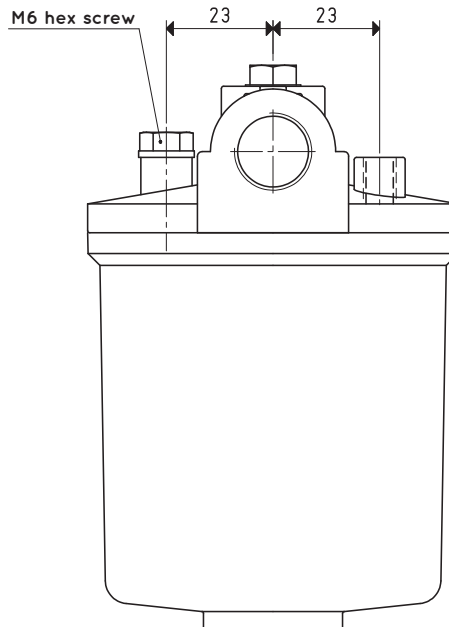
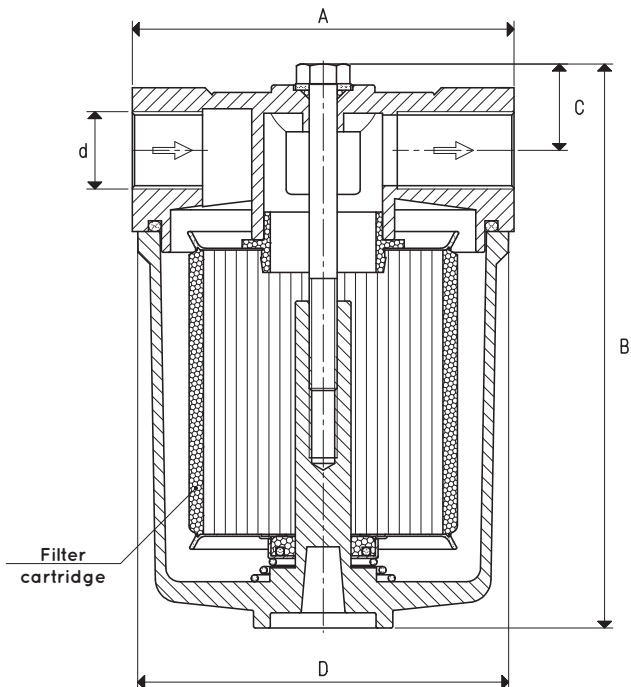

5

Item	d Ø	A	B	C	D Ø	Flow rate max m ³ /h	Cartridge spare part item	Sealing kit and small parts item	Weight g
FB 20 A	G1/2"	81	121	17	79	20	00 FB 22	00 KIT FB20	394

Transformation ratio: N (newton) = Kg x 9.81 (force of gravity)

inch = $\frac{\text{mm}}{25.4}$; pounds = $\frac{\text{g}}{453.6} = \frac{\text{Kg}}{0.4536}$

Adapters for GAS - NPT threading available on page 1.130